

# INSTRUCTION BOOK AND REPAIR LIST

SERIES No. 127



Read Page No. 30



*Keep This Booklet for Future Use*

**Every Hercules Engine is Carefully Tested  
and Inspected to Insure Our  
Customers 100% Service**

The life of your engine depends on the  
attention you give it. Please take advantage  
of the instructions we give you in this book.

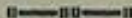

**Hercules Products, Inc.**  
Evansville, Indiana

---

Index—Page 64



### *Special Notice*

Watch your fuel and lubricating oil adjustment, it will save both fuel and oil and ignition trouble.

Too much fuel and oil may foul the spark plug. Black smoke or muffled sound at the exhaust indicates a rich mixture. (See pages 5, 6 and 10 on amount of oil to use and how to adjust the fuel.)

---

One copy of this Instruction Book furnished gratis with engine. Additional copies can be secured for 15c each. Stamps will be accepted.

## HERCULES KEROSENE ENGINE

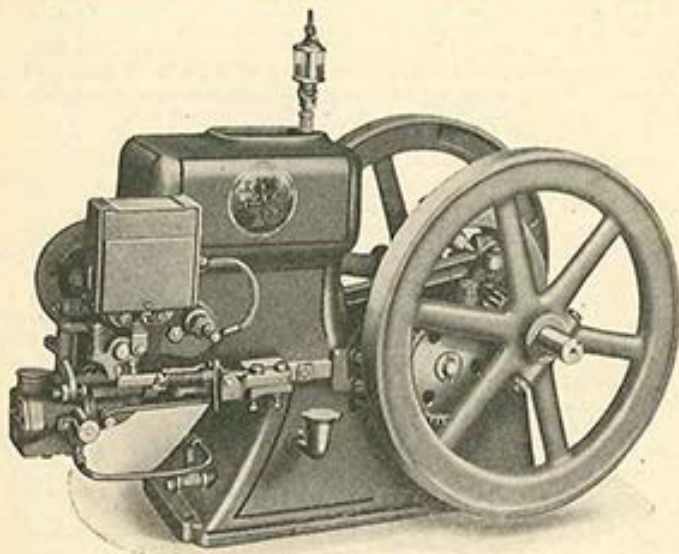

Figure 1  
1 $\frac{3}{4}$  and 2 $\frac{1}{2}$  Horse Power

These little engines are of the same sturdy construction and material as our 1 $\frac{3}{4}$  and 2 $\frac{1}{2}$  horse power gasoline engines and the rules for running, adjusting and caring for them are the same except the following instructions on the kerosene features.

#### TO START THE 1 $\frac{3}{4}$ AND 2 $\frac{1}{2}$ H. P. KEROSENE ENGINES

Read page 30 and proceed as follows:

**First.** Fill carburetor reservoir with gasoline, open gasoline throttle valve No. 0153A one full turn.

**Second.** Lift magneto spark lever No. 403 (see Fig. 12 or 13, page 36 or 37) up to starting position, this retards the spark which prevents the engine from kicking and makes it easier to start.

**Third.** Apply the starting crank and hold the intake valve in the cylinder head open with the left hand, spin the flywheel rapidly five or six times, then release intake valve but continue to crank the engine, as soon as you release the inlet valve place your hand over the air damper inlet on the carburetor so as to partly close the air intake until the engine starts.

**Fourth.** As soon as the engine starts firing, push the spark lever No. 403 down to running position.

**Fifth.** About the time the gasoline placed in the carburetor has been used up or the engine has become heated enough to run on kerosene turn on the kerosene by opening the kerosene throttle valve No. 0153 about one full turn and then close the gasoline valve and adjust the kerosene valve to the point where the engine runs best.

## HOW TO ADJUST THE BUTTERFLY VALVE ON THE 1½ AND 2½ H. P. KEROSENE ENGINES

Across the face of the butterfly spindle and damper lever No. 0167 you will find a line. This line should be parallel with the air damper rod No. 173 or thus—when the engine is idle. When the butterfly valve is in this position it is wide open and the governor spindle No. 068-C should just touch the end of set nut No. Y467, see page 34.

### HOW TO CHECK UP ON ENGINE TROUBLE

If your engine is not running as it should, look for the trouble in one of the four following places: ignition, rich mixture, lean mixture and timing.

If your engine is not firing regularly and does not develop its rated horse power, first remove the lead wire connecting the spark plug and the magneto, hold the end of the wire about ½-inch from the plug, turn the engine over a time or two until the magneto trips. If the spark jumps the gap with a good bright spark you will know that your trouble is not caused by the magneto.

You should next examine the spark plug, if the spark is coming through the plug as it should you will know that the trouble is not caused by the magneto unless the spark is occurring too early or too late. For adjusting time of spark, see page 14 (Faulty Ignition) and Fig. 11, page 31.

If black smoke appears at the exhaust muffler and the exhaust has a muffled sound the mixture is too rich and you are using too much fuel. If you cannot regulate this with the fuel valve by cutting off some of the fuel it will be necessary to loosen the air intake or damper spring by releasing the lock nut and turning the air damper stem, No. 1230-K, Fig. 10, page 31, to the right. This is a very sensitive adjustment and the damper stem should be turned but very little at a time until the desired results are obtained.

If there is a popping sound at the carburetor and engine does not develop its rated horse power the mixture is too lean. Do not try to adjust this by adjusting the carburetor until you have cleaned the fuel pipe and strainer No. 38 and 40. You will find a little valve in the fuel line; be sure that it is working freely. After you have assured yourself that the fuel line is cleared and the engine continues to show signs of lean mixture it will be necessary to adjust the air damper spring by releasing the lock nut and turning the damper stem to the left which will tighten the spring and make the damper disc harder to move thereby causing more fuel and less air to be drawn into the cylinder at each suction stroke of the piston. Be very careful not to make this adjustment too tight or you will flood the engine and make it necessary to make the adjustment all over again.

Do not try to make adjustments on the air damper spring until you have assured yourself that all other parts of the fuel system are properly adjusted.

If the engine starts and runs good on the gasoline you put in the carburetor to start the engine with and fails to run good when you turn on the kerosene, you will find your trouble somewhere between the carburetor and the fuel tank.

### TO ADJUST THE SPEED OF THESE ENGINES

Make all speed adjustments with speed change adjusting screw No. Y467, see page 31, Fig. 10. If engine runs too fast loosen lock nut on set screw No. Y467 and turn screw to the right. This shortens the distance between the end of screw and the end of the governor spindle rod causing the governor to close the butterfly valve and slow down the engine.

To increase the speed of the engine turn the adjusting screw to the left thereby increasing the distance between the screw and the governor spindle.

## HERCULES KEROSENE ENGINE

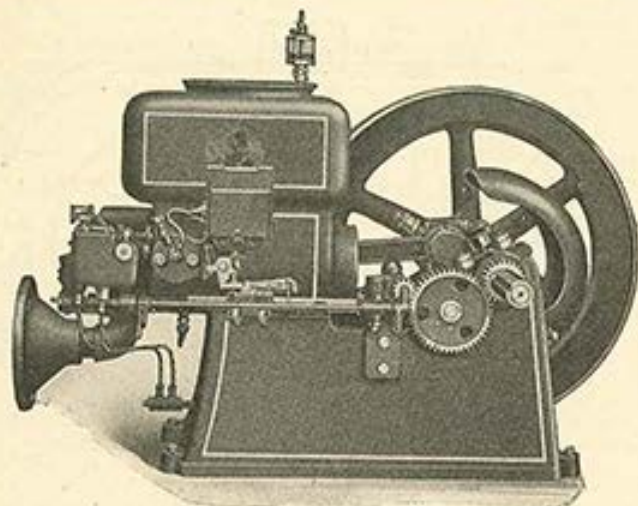

Figure 2

### The Following is a General Description of the Throttling Governed Kerosene Engine

Sizes 3½-6-8-10-14 H. P.

**CYLINDER.** Semi-steel, accurately machined and reamed to perfect "gun barrel" finish, fitted with ground piston and rings, insuring perfect compression and reducing friction to the lowest possible minimum. Cylinder is attached to main frame by means of machined tongue and groove method.

**MAIN FRAME.** Accurately machined, and reinforced across top under crank; contains heavy galvanized fuel tank.

**BEARINGS.** Main bearings, as well as crank pin bearing, are of high grade babbitt, Removable type, making it possible to replace them at any time.

**CAM.** Hardened steel attached to cam gear by being pressed over machined hub and riveted, can be replaced.

**GOVERNOR.** High speed, fly-ball type, pronounced by the most eminent authority in mechanical engineering as the most accurate as well as the most economical governor ever used on an internal combustion engine.

**FUEL SUPPLY.** The fuel is drawn from the supply tank by means of a pump, which is built into the carburetor, holding fuel supply at a constant level, insuring a perfect mixture at all speeds.

**SPEED.** The Kerosene Engine is equipped with an effective speed changing device which enables the operator to change ten, twenty, fifty or a hundred revolutions per minute while the engine is in operation.

The superior quality of the engine, the extremely attractive prices and the big saving in fuel cost, make this the most desirable engine obtainable.

## Kerosene Engine Instructions

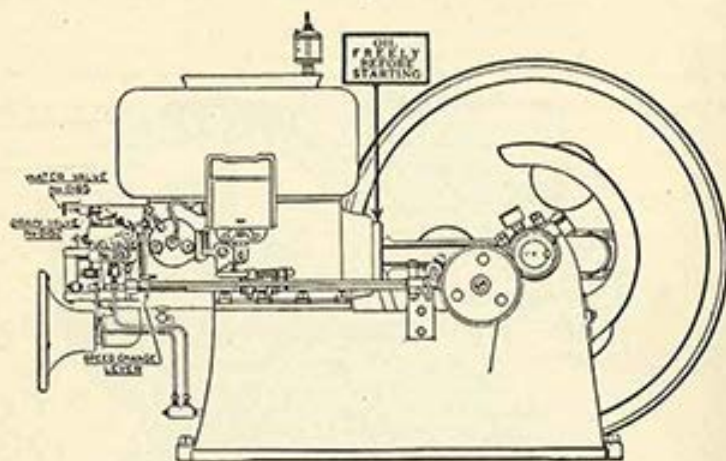

Figure 3

### Before You Start Your Engine Read the Following

#### HOW TO PREPARE KEROSENE ENGINE FOR STARTING

Remove the plugs from the holes in the main and connecting rod bearings, clean them out thoroughly, also any other oil holes that you find.

Fill the grease cups and screw the tops of the cups down until the grease starts to come out of the bottom. Then put the cups in place on the engine and turn the top down two full turns, which forces the grease into the bearings.

#### TO ADJUST THE No. 63 AUTOMATIC GREASE CUP

See Page 7, Figure 4

For summer use—cut down the amount of grease by turning the screw in the shank of the cup until the hole in the bottom of the cup is half closed. Fill the cup and before placing on the engine see how fast it feeds. A cup full of grease should last half a day.

For winter use—the hole in the bottom of the cup should be wide open. You can adjust the screw in the shank of the cup by trial, until you get the proper amount of grease for this bearing.

Oil all movable parts thoroughly and turn the flywheels around two or three times to work the grease into the bearings. Oil the valve stems and make sure they work perfectly free, feed oil to oil hole in cam, also be sure to oil the piston and let a few drops run down into the tube to piston pin.

Fill the tank in engine base with kerosene.

Put just enough water in the water hopper to cover the cylinder about 2 inches. If convenient use warm water in cold weather. Do not use boiling hot water, as you are liable to crack the cylinder.

Close drain valve and fill the carburetor reservoir to the overflow with gasoline. Screw the lubricator into the pipe on top of the water reservoir, fill it with oil.

## Kerosene Engine Instructions

Turn on the oil by raising the lever on the lubricator and adjust it so oil will flow freely. To increase the flow, turn adjusting collar just under the lever to the right; to decrease the flow, turn it to the left.

Drop small quantity of lubricating oil on plunger of fuel pump.

Before starting engine make sure all parts are properly oiled. Never use steam engine oil, use any good grade (high fire test) gas engine or tractor oil.

Under ordinary conditions we recommend that lubricator be set to feed as follows on both kerosene and gasoline engines:

| H. P.                  | On Full Load        | On Light Load       |
|------------------------|---------------------|---------------------|
| 1 3/4, 2 1/2 and 3 1/2 | 10 drops per minute | 5 drops per minute  |
| 6 and 8                | 20 drops per minute | 10 drops per minute |
| 10 and 14              | 30 drops per minute | 15 drops per minute |

In cold weather warm the oil so that it will flow freely.

#### DIRECTIONS FOR STARTING KEROSENE ENGINE 3 TO 14 H. P.

**First.** Open the fuel valve No. 0153 (page 4) one full turn, after engine is running adjust valve to mark on valve head.

**Second.** Lift magneto spark lever No. 403, as shown on page 37, Fig. 13, up to starting position. This retards the spark and prevents the engine from kicking.

**Third.** Apply the starting crank and hold the intake valve open with the left hand, spin the flywheel rapidly five or six turns, release the intake valve but continue to crank the engine. At the same time partly close the air intake in the bottom of fuel reservoir with fingers of left hand until engine starts.

**Fourth.** As soon as the engine starts push the spark lever No. 403 down to running position. This advances the spark.

We do not furnish starting cranks with the 10 or 14 horse power engines. Start these engines off compression, see paragraph below.

#### TO START ENGINE OFF COMPRESSION

**First.** Hold the intake valve open with the left hand and turn the flywheel to the right with the right hand until the igniter trips, then stop.

**Second.** Open the fuel valve No. 0153 (page 4) one full turn, after engine is running adjust valve to mark on valve head.

**Third.** Lift magneto spark lever No. 403, as shown on page 37, Fig. 13, up to starting position. This retards the spark and prevents the engine from kicking.

**Fourth.** Prime the cylinder by filling the priming cup twice with gasoline. In cold weather fill the cup three to four times, turn the flywheels to the right until the crank is on the outer dead center, then close priming cup.

**Fifth.** Take hold of the spoke in the flywheel at the top with your right hand and put your right foot on a spoke at the bottom. Pull with your hand and push with your foot, giving the wheel a quick turn back toward the cylinder, bringing the piston back against the compression as hard as possible. Release hold on flywheel with hand and foot and trip magneto with trip wire or with a screwdriver by placing it between the armature No. 100 as shown on page 37, and the magneto body and pushing downward.

**CAUTION**—Be sure to take hand and foot off flywheel before tripping magneto.

**Sixth.** As soon as the engine starts, shift the spark lever No. 403 to the running position. This advances spark.

## Kerosene Engine Instructions

### HOW TO GET THE BEST RESULTS AFTER ENGINE IS STARTED

Push the spark lever No. 403 downward to the running position.

After you have the engine started and the fuel valves properly set, start on whatever work you have to do and run on load until water in the hopper steams, then add a little water from time to time until the water hopper is full. The engine will give the best results when the water is hot, as heat helps to vaporize the kerosene.

### TURN ON WATER

only after the engine has become hot and is working hard and you notice a slight knocking in the cylinder at each explosion, which is characteristic of all kerosene engines. To overcome this, open the water valve (page 4) in cylinder head, one notch at a time until the pounding has nearly ceased. Be careful not to use too much water in trying to entirely stop the knocking, as a little knock indicates good power, and too much water causes loss of power. This does not apply to the  $1\frac{1}{4}$  and  $2\frac{1}{2}$  H. P. kerosene engines.

### HOW TO STOP KEROSENE ENGINE

Be sure to drain the Carburetor when stopping engine

**First.** Close the No. 0165 water valve about five minutes before stopping the engine. This prevents cylinder from rusting and makes the engine easier to start.

**Second.** Close the fuel valve by turning to the right as far as it will go.

**Third.** Shut off the oil.

**Fourth.** Open the drain valve No. 0152. (See page 34.)

**Fifth.** Turn flywheel until exhaust valve closes. This prevents corroding of valve seats and injury to cylinder.

In cold weather be sure to drain all the water out of the water hopper by opening the drain cock underneath the cylinder. Also remove No. 27 plug from bottom of cylinder head. Be sure to do this, as even a light frost may crack the cylinder or head by freezing the water.

If you are working your engine on a big job running all day, when you shut down at noon your engine will be very hot. If you do not take more than an hour for lunch—when returning to work you can start the engine on kerosene direct and will not have to use gasoline, as the engine will be hot enough to start on kerosene, in which case it will not be necessary to drain the carburetor reservoir when stopping the engine.

### HOW TO ADJUST KEROSENE CARBURETOR ON THE $3\frac{1}{2}$ -6-8-10 AND 14 H. P.

The kerosene carburetor is of the pump feed type. Kerosene being pumped up from the tank in the base by action of cam rod on pump lever.

The fuel is mixed with air drawn in from beneath carburetor and the feed to the cylinder head is regulated by a "butterfly" type valve.

Too little fuel will cause a popping sound at the mixer.

Too much fuel will cause a discharge of black smoke from muffler.

In case engine is not getting enough fuel after you have properly regulated fuel valve, drain carburetor by means of drain valve, remove No. 0158 pump body, taking care not to lose the two check balls, and clean pump body and connection carefully.

To adjust the butterfly valve in air damper cage, put the speed change lever No. 0157 in low speed, and with the left hand raise the throttle lever No. 0156 till the butterfly valve No. 170 in damper cage is wide open. This can be de-

## Kerosene Engine Instructions

termined by the mark on this valve, as it must be in a horizontal position. With the right hand push the governor shaft arm No. 0154 tight against the end of the governor spindle rod No. 068 and in this position tighten the set screw on the governor shaft.

### THE GOVERNOR

The throttling governor engine is also designed with the ball type governor. It is very sensitive and acts directly on a butterfly valve in the fuel passage going to the cylinder head, which regulates the amount of fuel and air admitted to the cylinder in proportion to the load on the engine, maintaining constant speed with the least fuel consumption under all conditions. When running empty or on a load this type engine exhausts every second revolution of the flywheels.

Always make certain that cam rod does not bind and works freely through pocket in governor bracket.

Always keep the speed lever set at high speed, as this runs the engine at its regular speed, where it will give its full power. If you reduce the speed of the engine you also reduce the power it will develop. Never slow the engine down on a heavy load. If you want less speed for heavy work get a smaller pulley.

By means of the speed regulator you may slow your engine down about 100 R. P. M. (See page 56 for rules for determining the size of pulleys to use.)

### THE AUTOMATIC CONNECTING ROD GREASE CUP

To fill and adjust this cup, screw the lever "A" down as far as it will go. Then unscrew the cup at "B". With a screwdriver turn the screw in the shank "C" to the right until the hole through the bottom of the cup is closed.

Fill the cup with grease. Screw the two parts of the cup together securely and turn lever "A" to the left until it reaches the position "D". Then take the screwdriver and turn the screw "C" slowly to the left until the grease starts to come out slowly. Then screw the cup in position on the connecting rod. This cup should be readjusted for hot or cold weather. One filling should be enough for about eight hours' continuous running.



Figure 4

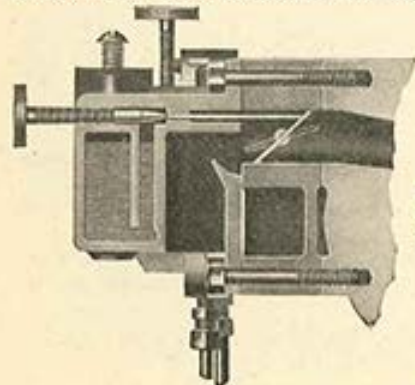

Interior view of the kerosene carburetor for the  $3\frac{1}{2}$ -6-8-10 and 14 H. P. engines showing the position of the butterfly valve and spray nozzle.

# HERCULES GASOLINE ENGINE

CONSIDER THE QUALITY BENEATH THE PAINT

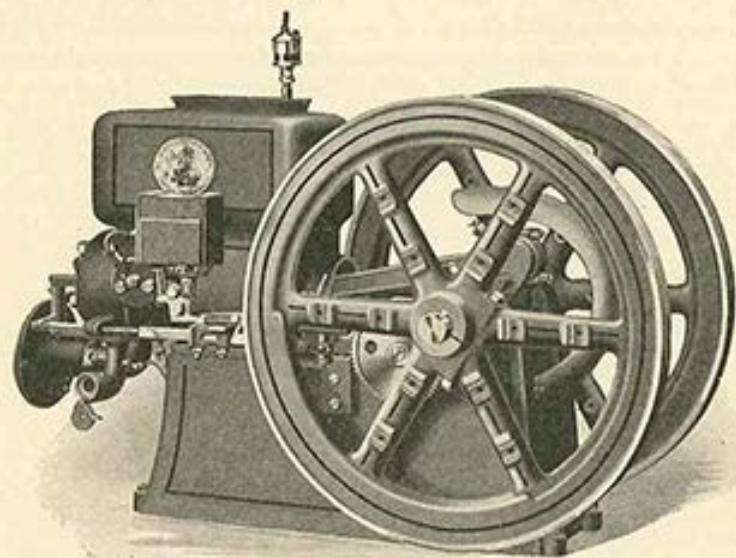

**CRANK SHAFT.** Drop forged high carbon steel. 10% oversize. Turned and ground.

**GEARS.** Governor gear and crank shaft gear are cut from solid blocks of steel.

**BEARINGS.** White Bronze, die cast removable and interchangeable. Best automobile motor bearings are exactly the same. Compare this with cheap babbit melted and poured into the rough castings around the shaft, the method used in the manufacture of practically all other low-priced engines and a great many of the high-priced ones.

**GOVERNOR WITH SPEED CHANGING DEVICE.** High-speed fly-ball type as used on highest-priced engines. Equipped with speed changing device that enables the operator to change the speed 125 R. P. M. while engine is in operation by merely shifting a vertical lever.

**FINISH.** All castings are ground smooth, given several coats of filler, thoroughly sanded, painted and varnished, producing a wonderfully smooth and attractive finish.

Every man takes pride in realizing the fact that he has made a good purchase. Our customers do our advertising.

## Gasoline Engine Instructions

### TO GET ENGINE READY TO RUN

Remove the plugs from the holes in the main and connecting rod bearings, clean them out thoroughly, also any other oil holes that you find.

Fill the grease cups with the sample grease we furnish and screw the tops of the cups down until the grease starts to come out of the bottom. Then put the cups in place on the engine and turn the top down two full turns, which forces the grease into the bearings.

Oil all movable parts thoroughly and turn the flywheels around two or three times to work the grease into the bearings. Oil the valve stems, feed oil to oil hole in cam, also put a few drops on the igniter parts and work these parts by hand to be sure they are free from paint.

Fill water hopper with clean water and the tank in the base with gasoline. Screw the lubricator into the pipe on top of the water reservoir, fill it with oil. Raise the lever on the top of the lubricator straight up and adjust it so the oil will drop freely. To increase the flow of oil turn the adjusting collar, just under the lever to the right; to decrease the flow turn it to the left.

Before starting engine make sure all parts are properly oiled. Never use steam engine oil; use a good grade (high fire test) gas engine oil. For quantity see page 5.

To adjust the No. 63 Automatic Grease Cup see page 7, Figure 4.

### FIRST METHOD OF STARTING GASOLINE ENGINE

**First.** Open the needle valve on mixer two full turns to the left, close the air damper, turn on the oil by raising the lever on the lubricator and be sure the oil is dropping properly.

**Second.** Lift magneto spark lever No. 403 as shown on page 37, Fig. 13, up to starting position. This retards the spark and prevents the engine from kicking.

**Third.** Turn the flywheels to the right until the detent blade on the governor can be pushed in behind the catch block on the cam rod and hold it there.

**Fourth.** Apply the starter crank and turn it around to the right rapidly five or six times and then release the detent blade, but continue to turn the flywheel until the engine starts.

Starting cranks furnished with 1½, 2½, 3½, 6 and 8 horse power engines only.

**Fifth.** As soon as engine starts open the air damper, change the spark lever No. 403, Fig. 13, to the running position and close the fuel valve slowly until the point is reached where the engine runs with the least number of explosions and without black smoke appearing at the exhaust or a popping sound at the mixer, the latter being caused by an insufficient supply of fuel, and smoke at the exhaust by too much fuel.

### METHOD OF STARTING GASOLINE ENGINE ON COMPRESSION

This does not apply to the 1½ or 2½ horse power as no priming cup is furnished on that size.

**First.** Open the priming cup to relieve compression and turn on the oil by raising the small lever on top of the lubricator.

## Gasoline Engine Instructions

**Second.** Place the spark lever No. 403, (Fig. 13) in the starting position and turn the flywheels to the right until the igniter trips, then stop.

**Third.** Prime the cylinder by filling the priming cup four times with gasoline and let it run into the cylinder, then close the cup. If the engine has been running and is still hot only fill the cup once.

**Fourth.** Open needle valve on the mixer two full turns to the left, close the air damper and then turn the flywheel to the right one-half turn or until the crank is on the outer dead center.

**Fifth.** Take hold of a spoke in the flywheel at the top with your right hand and put your right foot on a spoke at side nearest the magneto, pull with your hand and push with your foot, giving the flywheel a quick turn back toward the cylinder, at the same time trip the magneto with trip wire or with a screwdriver by placing it between the armature No. 100, as shown on page 37, and the magneto body and pushing downward which should start the engine.

Starting cranks furnished with 1 $\frac{3}{4}$ , 3 $\frac{1}{2}$ , 6 and 8 horse power engines only.

**Sixth.** As soon as the engine starts open the air damper on the mixer, shift the spark lever No. 403, to the running position and close the fuel valve slowly until the point is reached where the engine runs with the least number of explosions, as explained above.

### HOW TO ADJUST THE GASOLINE FUEL VALVE

The mixing valve (Figure 5) is of the suction feed type, gasoline being drawn from the tank in the base by the suction of the piston. The air and gasoline are mixed in this valve to form the explosive gas.

When you start the engine, open the fuel valve, close the air damper and turn the flywheel to the right; this draws a supply of gasoline from the tank and primes the valve. It is a common mistake to flood the cylinder in starting engine. Open fuel valve 2 turns on 1 $\frac{3}{4}$  and 2 $\frac{1}{2}$  H. P. engine and from one to two turns on the larger sizes. In cold weather use more fuel. After the engine is running, open the air damper and close the fuel valve slowly until the point is reached where the engine runs with the least number of explosions and without black smoke appearing at the exhaust, or a popping sound at the mixer, the latter being caused by an insufficient supply of fuel, and smoke at the exhaust by too much fuel.

If it is ever necessary to take the mixing valve and feed pipe off the engine, be very careful not to lose the valve out of the check valve, because if this valve is not in place your engine will not get any gasoline. To drain gasoline from tank remove drain plug. (See Figure 5.)

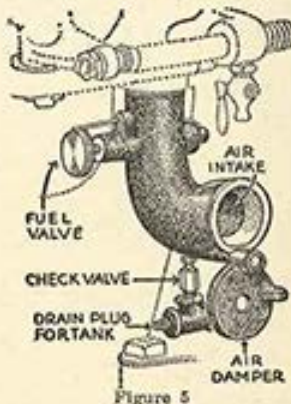

## Gasoline Engine Instructions

### THE GOVERNOR

The governor controls the speed of the engine and is of the ball type. When the engine runs above its regular speed, the balls on the governor widen their circuit, which presses in on the pin going through the governor spindle. This forces the detent blade in so that it catches behind the block on the cam rod and holds the exhaust valve open, at the same time stopping the spark and cutting off the supply of fuel, until the speed of the engine is reduced to where it should be, then the detent blade flies out again, releasing the cam rod and the engine takes up its regular operations. When running empty the engine exhausts every eight to ten revolutions of the flywheel.

### HOW TO ADJUST THE DETENT BLADE

When the exhaust valve is wide open and the detent blade is pushed in behind the catch block on the cam rod, there should be only the thickness of a postal card between them. When adjusting the detent blade, the speed lever should be set at lowest speed and the detent blade should stand about  $\frac{1}{8}$ -inch away from the catch block.

To adjust the detent blade loosen the locknut "No. 077" and screw the adjusting screw "052" either in or out, until you have the blade where it should be, then tighten the locknut. See page 34.

### THE DETENT CATCH BLOCK

The catch block on the cam rod is made of tool steel and should last a long time. If the block should wear on one side so it does not hold the detent blade properly file off the point of screw where it is riveted on side of rod next to the engine, remove the screw with a screwdriver and turn the catch block around, using the other side. After both sides of the block are worn, it will be necessary to replace same with a new one. (See No. 054 in list of repairs, page 26.)

### TO STOP THE ENGINE

**First.** Shut off the gasoline by closing the fuel valve.

**Second.** In cold weather drain the water from the reservoir by opening the drain cock underneath the cylinder, also remove plug from bottom of cylinder head. Be sure to do this, as even a light frost may crack the cylinder or cylinder head by freezing the water.

**Third.** Turn flywheel until exhaust valve closes. This prevents corroding of valve seats and injury to cylinder.

# Kerosene or Gasoline Engine Instructions

## TO START IN COLD WEATHER

All engines are harder to start during cold weather than in warm weather, because gasoline does not vaporize as readily in cold weather. You can overcome any difficulty from this cause in starting by pouring a couple of gallons of warm water in the water reservoir; this warms up the cylinder, causing the gasoline to vaporize more readily. (Be careful if engine is real cold not to use water too hot, as the sudden change may crack the cylinder.) It is also advisable to open the fuel valve farther than you generally do, and be sure to close the air damper when starting; also put a teaspoonful of gasoline in the cylinder through the priming cup if the engine has one. Work the intake valve in and out before starting in cold weather, as this will remove any frost that may have collected on the valve stem and allow valve to work easily.

## IF THE WATER IN THE HOPPER SHOULD BOIL

The hotter the water gets, the better the engine runs, because the gasoline vaporizes more readily and the engine will use less gasoline. The cylinder is cooled by the water circulating around it and the heat passes off in the form of steam, so if the water boils, you need not be alarmed. Keep the cylinder properly lubricated and the reservoir full of water and there will be no danger of your engine overheating. **IN COLD WEATHER DRAIN BOTH THE CYLINDER AND CYLINDER HEAD AT NIGHT TO PREVENT FREEZING.**

## Stop—Look—Listen

If your engine does not give perfect satisfaction, do not call in an expert—read the following:

Every engine is carefully tested and inspected to insure our customers 100 per cent service.

Just before we shipped your engine it was gone over carefully and run to be sure that all parts were in proper adjustment and in perfect condition, so that when the engine reached you there would be no trouble in your running it, provided you did not change any of the parts from the way they were set when the engine left our factory.

## If Engine Will Not Start or is Hard to Start

An engine to give satisfactory results must get a good mixture of fuel and a good spark, at the proper time, inside the cylinder.

To do this, it is absolutely necessary that you use the proper amount of fuel that is free from water, and there is no obstruction to prevent its flow. Read very carefully the following paragraphs: Fuel, Clean Connections; Water in Fuel; Too Much Fuel and Too Little Fuel (page 13.)

The water valve be closed as instructed on page four, paragraph on how to stop Kerosene Engine.

# Kerosene or Gasoline Engine Instructions

See that the valves are properly timed: Read very carefully paragraph on Valve Timing (page 17).

See that the magneto furnishes a spark and that it takes place just as the word "spark" passes the top edge of the valve rod as shown in Fig. 15, page 50.

The butterfly valve in air damper cage and the governor shaft arm should be properly adjusted. (See last paragraph on page 6.)

## FUEL, CLEAN CONNECTIONS

Make certain there is plenty of fuel in tank.

See if the fuel flows to the mixing valve. Dirt sometimes gets into fuel pipe and collects on the fuel valve or under the check valve. Clean all connections carefully.

If you find the mixing valve or connections are dirty, drain the tank by removing the plug and strain the fuel through a chamois skin, which will keep out the dirt and water.

## WATER IN FUEL

Water in fuel will cause loss of power. The presence of water is rather hard to detect, but if doubtful you can make certain by straining the fuel through a chamois skin. This is rather dangerous, however, as the gasoline, being a volatile substance, in passing through the chamois forms static-electricity, which will cause spark unless the funnel fits securely on a conducting material which is properly grounded; in other words, if the funnel fits securely on the mouth of the tank which is properly grounded on engine, you will need fear no danger from this source.

## TOO MUCH FUEL

It is a common mistake to flood the cylinder in starting engine, which makes it very hard to start. Unless engine is subjected to a low temperature, do not flood the cylinder, as engine can be choked down by feeding too much fuel just as easily as by not feeding enough. If fuel is subjected to low temperature, the rate of vaporization is much lower and an extra amount of fuel is necessary.

## TOO LITTLE FUEL

If engine is not given the proper amount of fuel there will be a popping and back-firing out of air inlet; however, this popping noise is also caused by poor ignition, valves not seating properly, or poor mixture. It is possible that the head gasket has given out, allowing water to leak out and mix with the fuel; if so, it will be necessary to replace with a new gasket. Generally, the leak is so slight that after engine has once been started the leak is not noticeable.

## IGNITION

Be sure the magneto wires are properly attached, in good condition, and that a bare wire does not touch any part of the engine except the spark plug.



## Kerosene or Gasoline Engine Instructions

### If Engine Dies Down After Starting

#### LACK OF FUEL

See that there is proper amount of fuel in tank.

#### FAULTY IGNITION

Examine spark plug to be sure you are getting a good spark. Remove it, but leave it connected to the wire, place it against the side of cylinder, trip the magneto, (see page 10, paragraph 5). If you do not get a good spark clean the spark plug. See that the points on the plug are not farther than the thickness of a thin dime apart, next examine the magnet post in the bottom of the magneto body, remove all dirt or rust from these posts if you fail to get a spark. (See page 48.)

### If Engine Has No Power

#### SPARK REGULATION

Have you advanced spark; that is, have you placed spark lever No. 403 back in running position after you have started engine?

#### FAULTY IGNITION

Make certain that the magneto trips when the word "spark", which you will find stamped on the rim of the flywheel, is opposite top of cam rod.

If magneto does not trip at right time loosen set screws Nos. Y15 or Y586 (see pages 36 and 37) and lengthen or shorten the distance the latch finger has to travel by adjusting castings Nos. K198-B and O198-B with adjusting screw No. Y460, (see pages 36 and 37).

#### POOR MIXTURE

The greater percentage of causes of lack of power can be traced down to a poor mixture. If the charge is not mixed properly, it makes a slow burning mixture which will, in most cases, cause back-firing, owing to the charge burning so slowly that it fires the incoming charge, which, of course, would naturally escape back through the mixer on account of inlet valve being open.

Owing to the variance in atmospheric conditions, there is no certain point at which the needle valve may be adjusted; however, if you will carefully watch action of engine and adjust it at a point at which the engine runs most regularly, and without excessive exhaust, you will have no trouble along this line.

If you are using kerosene oil, make certain that you are feeding the proper amount of water to carburetor. Too much water will cut down the power; too little water makes a poor mixture, which burns slowly, resulting in late combustion, which besides causing a loss of power, and leaving an excessive deposit of carbon on the cylinder wall, heats up the engine to such an extent that a pounding results, commonly called pre-ignition. This pounding can always be nearly eliminated by feeding a little water to carburetor. Pre-ignition is indicated by a deep, heavy sound and is generally either caused by a poor mixture, hot cylinder or a red hot deposit in cylinder.

## Kerosene or Gasoline Engine Instructions

If pre-ignition does not seem to be due to poor mixture or a hot cylinder, it is evidently due to an excessive deposit of carbon in the combustion chamber. However, this trouble can generally be eliminated by running engine a short time on denatured alcohol; if this does not eliminate the trouble, remove the head and clean combustion chamber thoroughly.

Test fuel for water. Water in fuel will cause loss of power. See page 13.

Make certain that the exhaust valve is closing on inner center. See page 17.

If valves do not seat properly, remove same and grind them down so that they fit the valve seats properly. This adjustment is fully explained on page 17.

#### MISCELLANEOUS

Make certain that the working parts, such as gears, governor, etc., are properly oiled. It is well to examine the oil tube in piston from time to time and make sure that this is not clogged up.

In cold weather, much attention must be paid to lubrication. If the oil is subjected to low temperature it will have a tendency to thicken to such an extent that it will not flow freely down oil pipe. In such cases, it is well to warm the oil before starting.

Oil the governor so that it works freely; also feed the proper amount of oil to oil hole in cam and to the pocket in governor bracket through which cam rod works.

If after going over the adjustment of each part according to the instructions in this book, you cannot get the engine to run satisfactorily, write us a letter. Tell us just what you have done, just how the engine acts, and we will tell you by return mail just what to do.

If in writing you refer to any certain part, give the regular repair list number of same so we will know exactly what you are referring to.

#### HOW TO PUT ON THE CAM GEAR

If it is ever necessary to take off the cam gear or to put on a new one it must be put on in a certain position, as the cam on the gear controls the time of the spark and the opening and closing of the valves, in fact every operation of the engine depends on this cam being set just right.

To put on the cam gear, hook detent blade back of catch block, turn flywheels around until the key in the crank shaft is straight up, as shown by "B" in Figure 6; then set the two teeth that are just under the indicator "A" on the cam gear over the one tooth that is just above the Key "B", then roll the cam gear around to the right until it reaches the position as shown by dotted gear, being sure to keep the gear teeth together. Then slip the cam gear pin in place and fasten it with the lock washer and nut.

Be very careful in putting on this gear to see that it is just right. One tooth out of the way makes a decided difference in the way your engine will run.

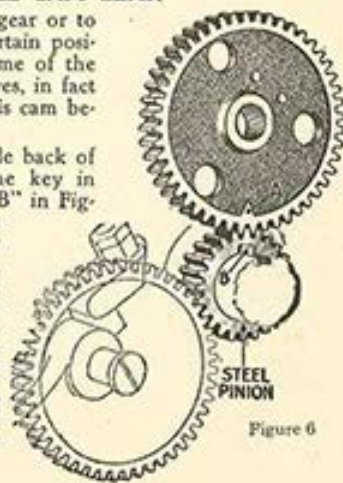

Figure 6

## Kerosene or Gasoline Engine Instructions

### HOW TO PUT ON THE CAM ROD SPRING

The cam rod spring holds the cam rod and roller against the cam on the cam gear. As this spring does a lot of work it may wear out; if it does, buy a new one. (See No. 059 in list of repairs, page 28.) To put on a new spring, remove the cylinder head, slip the spring over the end of the cam rod and replace the cylinder head. If necessary to repack cylinder head, see page 18.

### HOW TO TAKE OFF A FLYWHEEL OR PULLEY

To take off the flywheel, loosen the bolt and drive iron or wooden wedges into the slot, one on each side of the hub. This will loosen the flywheel so it can be removed. To take off the pulley on the  $1\frac{3}{4}$  horse power engine loosen the set screw with a screwdriver and drive the pulley off.

If you have to drive the flywheel or pulley off the shaft, use a piece of hard wood against the hub of the wheel and do not drive too hard. A number of light blows will loosen the flywheel without danger of breaking.

To remove the friction clutch pulleys, see page 24.

### HOW TO REPLACE A FLYWHEEL

When replacing flywheel, place wheel in proper position on shaft, tighten the bolts down securely and drive in key.

To replace the friction clutch pulleys, see page 24.

### TO TAKE OFF THE GOVERNOR BALLS, SPINDLE OR PINION

If you find it necessary to take the governor apart, first take off the governor pinion. To do this, hold the flywheels stationary, which locks the gears, then take a wrench, stand on the governor side of the engine and turn the governor balls to the right, as the pinion is put on with a right hand thread. The governor spindle screws into the governor pinion and is held in place by a small set screw in the governor pinion.

### VALVES

The inlet valve "A", as shown in the illustration is opened by the suction of the piston. For the entire length of the suction stroke gas is being drawn into the cylinder; then when the piston starts to compress the gas this valve closes and is held shut by the valve lock "C", so that no gasoline is wasted.

If there is a loss of fuel at the opening of the mixer loosen the locknut on the valve lock stud "C" and screw stud out one turn and tighten locknut. If engine does not get enough fuel loosen locknut as above and screw stud in one turn and tighten locknut.



Figure 7

## Kerosene or Gasoline Engine Instructions

### VALVE TIMING

In many cases where engine is hard to start, trouble can be traced to the valves not being timed properly.

As this is a four cycle engine, we will show you the four distinct parts in the movement of the piston and crankshaft and the timing of the valves.

The first is known as the suction stroke, during which time the piston is traveling from extreme inner to extreme outer position, causing a vacuum which automatically opens the inlet valve and admits a charge of kerosene mixed with air from the carburetor.

In the next or compression stroke, the piston returns from extreme outer to extreme inner position, compressing the charge which has been drawn into the cylinder. During this stroke both valves remain closed. The spark taking place just before the end of this stroke.

The third, or power stroke, is caused by the force of the explosion in the cylinder driving the piston out again to its outer position. Before the piston reaches the extreme outer position the exhaust valve is opened by means of a cam which pushes out the cam rod and works the valve lever and lifts the valve. The proper time for this valve to start to lift is when the crankshaft is half way between the vertical and horizontal position on the downward part of this stroke.

We now come to the last or exhaust stroke. The exhaust is already open so as piston returns from its outer position it drives the burnt gases out into the exhaust pipe. The exhaust valve remains open until the crankshaft has passed the inner center  $3^\circ$  or  $5^\circ$ .

This adjustment is controlled by means of No. 06 adjustment screw (page 32), and is easily regulated.

Notice the setting of this valve from time to time, as this may work out of adjustment as the engine is used.

If exhaust valve spring has weakened to such an extent that suction is pulling in exhaust valve, replace with new spring.

When cam rod is not in contact with No. 06 adjusting screw, the No. 24 valve lock lever should not bind on either valve stem. This can be easily regulated by readjusting the "C" valve lock stud. See illustration on opposite page, also page 31, Figure 11, for valve timing.

### HOW TO GRIND THE VALVES

When an inlet or exhaust valve leaks, remove the cylinder head, take off the valve springs, remove the valve you want to grind and wash it and the valve seat in gasoline, then make a paste of fine emery dust and oil. If you cannot get emery dust, use powdered pumice stone with oil. (You can get powdered pumice stone at almost any drug store.) Smear this on the valve and valve seat, put the valve in place and put a nail through the hole in valve stem on the outside of the head, grasp the nail with your fingers and turn from left to right for a minute or so, then lift the valve and turn it about half way around and repeat this until the valve and valve seat show an even surface all the way round.

After the valve is ground in, wash off the emery dust with gasoline and do not get any dirt on the valve seat. In replacing the valves be sure to get the heavy spring on the exhaust valve and the light spring on the inlet valve.

## Kerosene or Gasoline Engine Instructions

### PACKING THE CYLINDER HEAD

We use a special graphite asbestos packing between the cylinder and cylinder head to prevent the escape of the compressed gas.

To repack the cylinder head in case the packing should blow out or if you should break the packing when removing the cylinder head, you can use ordinary asbestos packing such as you buy at your hardware store or the kind we furnish under No. 17 on page 32. If you use the ordinary asbestos packing, soak it in linseed oil; if you buy our special graphite asbestos packing or gasket, it is all ready to be put on.

Before putting on new packing be sure all particles from the old packing which may have stuck to the cylinder or cylinder head are scraped off and that these parts show a smooth, clean surface. If all the old particles are not cleaned off the new packing will blow out in a short time.

After you have the packing in place push the cylinder head in close to the cylinder and screw on the nuts by hand as far as they will go, then use a wrench and turn each nut, one after the other, about one-half turn at a time. Do not screw one nut down perfectly tight and then go to the next, as this causes an uneven joint and the packing will not hold. After the engine has been running for about ten minutes tighten the nuts again and you will have a perfectly tight joint.

### CYLINDER HEAD PACKING

If you make a new packing from sheet asbestos you must be sure to cut openings in the packing so the water can circulate from the cylinder, through the cylinder head and around the valves; if you fail to cut these water openings the cylinder head will get too hot and be ruined.

### BEARINGS

Be sure all bearings are kept properly adjusted. An engine should never be run with a bearing that is too loose or too tight. A loose bearing will soon rack your engine and break something, and a tight bearing will heat up and soon melt.

The main bearings and crankshaft end of connecting rod have die cast bearings which fit perfectly into the machined bearings. The piston end of the connecting rod has a cast bushing.

All the bearings can easily be replaced; the bearing in the piston end of the connecting rod can be driven out and a new one driven in.

The crankshaft bearings and the bearing in the crankshaft end of the connecting rod are made of a special die cast babbitt. They are fitted with steel liners so you can take up any wear in the bearings. Remove the bearing cap and take out enough of the steel strips from both sides of the bearing so it fits snug.

After you have removed the steel strips and put the cap back on again, screw down the bolts, but before starting the engine open the exhaust valve by pushing the detent blade in behind the catch block on the cam rod and turn the flywheels around by hand to see that they turn freely. If they bind you have taken out too many steel strips and you will have to put enough back until the flywheels turn easily. Watch the grease cups closely and give them a quarter of a turn each time you start the engine. See that all bolts are tight and you will have no trouble with the bearings.

## Kerosene or Gasoline Engine Instructions

### PISTON AND RINGS

As explained on page 14, what makes the engine run is the combination of air and gas drawn into the cylinder by the suction of the piston, this gas being compressed before it is exploded. To compress this gas it is necessary that the space in the cylinder be gas-tight. The piston is fitted to the cylinder and makes a fairly tight joint, but on account of the expansion of iron when it gets hot, it is necessary to have some other means of keeping the gas from escaping. Each piston is fitted with three rings that spring out and press against the walls of the cylinder, preventing the gas from escaping.

These piston rings hold the compression and must fit free in the grooves of the piston. Feeding a poor grade of gasoline or lubricating oil, or too much of either, will cause a carbon deposit to form around the rings, which will in time bind them in the grooves, so they cannot spring out against the walls of the cylinder to hold the compression. It is very necessary that you use the proper grade of oil and watch the supply of gasoline, for on this depends the proper running of the engine.

Before removing the piston from the cylinder, be sure the wire is disconnected from the batteries or magneto, take out the connecting rod bolts at the crankshaft end of the connecting rod. Remove the bearing which loosens the connecting rod from the crankshaft. Next, you will have to take off the governor spindle, as instructed on page 16, which gets the spindle and balls out of the way. This is all of the governor that you will have to take off, as the piston will now slip out of the cylinder.

If you find the piston rings are gummed or held tight in the grooves, they must be thoroughly cleaned. To do this you will have to remove the rings and wash them in kerosene or gasoline and you may have to scrape them with a knife.

To remove the rings take three thin metal strips (pieces of an old hack saw blade are fine for this) and slip under the center ring. Start the first strip under the ring at the joint and force it all the way around until you have it at the position shown by "A", Figure 9, then slip the second strip to "B" and the third to "C", which will raise the ring out of the groove so it can be slipped off. Take the top ring next and repeat the operation, then the bottom ring.

In replacing the rings, put the center ring on first, using the three metal strips as before, then without the three metal strips you can slip the top ring on and then put the bottom ring on, bringing it up from the bottom of the piston. Before putting the piston back in the cylinder, oil the rings and surface of the piston thoroughly.

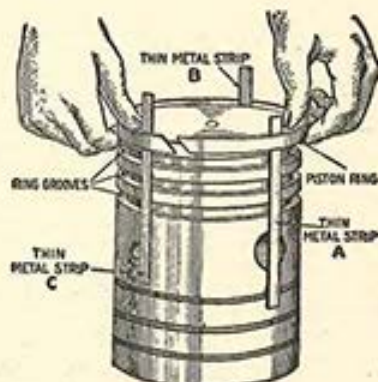
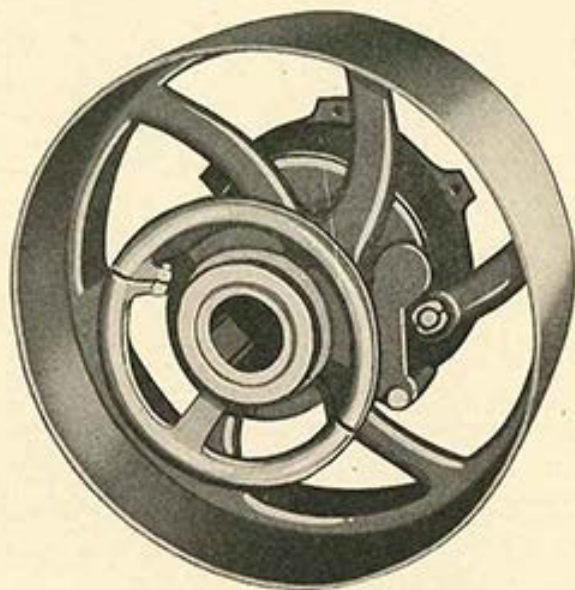

Figure 9

## The *HERCULES* Band Type Friction Clutch Pulley

—

Designed on the same principle as the Automobile Brake—with but one adjustment.



## The Hercules Band Type Friction Clutch Pulley

This pulley was designed and built by The Hercules Corporation to be used on its engines where a Friction Clutch Pulley is required.

This pulley is especially adapted for use with our engines and was designed by our engineers after several years' experience with various types of friction clutch pulleys.

The Clutch feature of this pulley is a tempered spring steel band lined with Brake Lining operating on a heavy cast drum which is also the main frame for the pulley.

The lining of this Steel Brake Band is practically the only part subject to wear and can be easily replaced at a very small cost. This makes our pulley a "long life" pulley.

This pulley is easily operated by pulling out and pushing in on the handwheel which is designed and located in such a way as to make it easy to operate.

The pulley is made in two styles: namely, the Light Duty and Heavy Duty type.

The Light Duty type is made in one size only with pulley rim twelve inches in diameter with a six inch face.

The Heavy Duty type is designed to give you a selection of four different size rims as follows: 16 x 8, 20 x 8, 24 x 8 and 29 x 8. These rims are all interchangeable on the Heavy Duty type.

—

### INSTRUCTIONS

To adjust this pulley loosen or tighten nuts as required on adjusting screw No. LH9 which is directly connected to the brake band and is the only adjustment on the tension of this pulley.

To insure long life, keep the moving parts of the pulley well oiled with the exception of the Brake Band which should be kept as free from grease and oil as possible.

## Hercules Band Type Friction Clutch Pulley Parts with Numbers

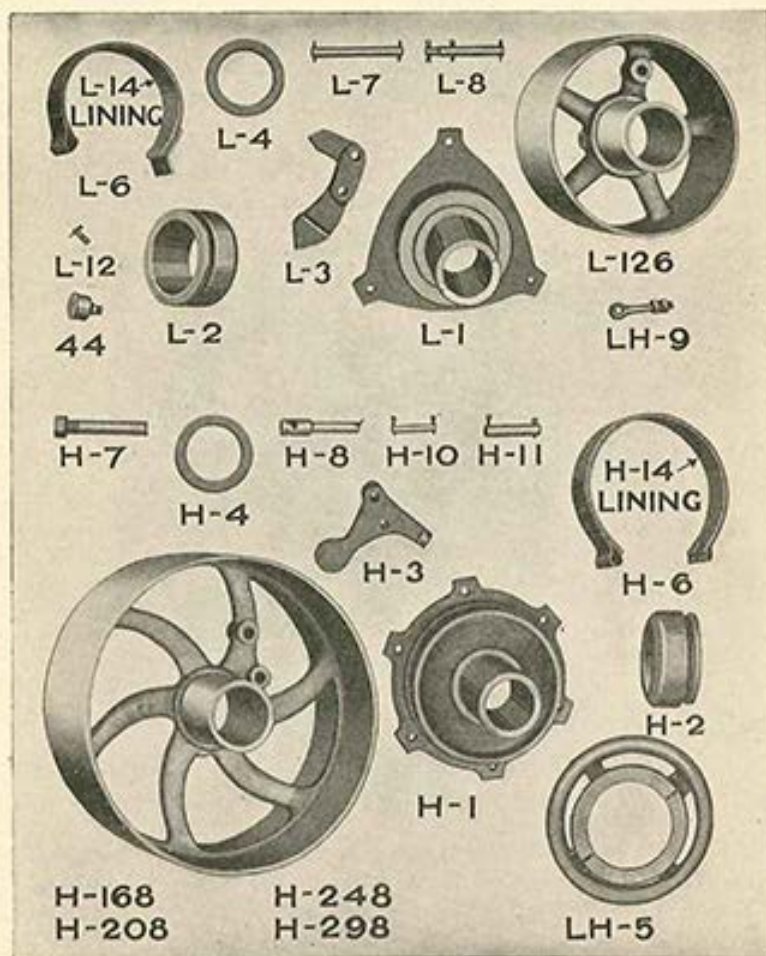

Always order by number and name.

## Repair Part Prices for Hercules Friction Clutch Pulley

|        |                                          |         |
|--------|------------------------------------------|---------|
| L126   | x12 x 6 Pulley Rim.....                  | \$10.80 |
| H168   | x16 x 8 Pulley Rim.....                  | 12.75   |
| H208   | x20 x 8 Pulley Rim.....                  | 15.30   |
| H248   | x24 x 8 Pulley Rim.....                  | 18.00   |
| H298   | x29 x 8 Pulley Rim.....                  | 20.95   |
| L1     | xSpider .....                            | 7.85    |
| H1     | xSpider .....                            | 9.65    |
| L2     | *Expander Collar.....                    | 4.70    |
| H2     | *Expander Collar.....                    | 4.80    |
| L3     | *Clutch Finger.....                      | 2.20    |
| H3     | *Clutch Finger.....                      | 2.20    |
| L4     | *Collar .....                            | 2.15    |
| H4     | *Collar .....                            | 2.30    |
| LH5    | *Hand Wheel with Bolts.....              | 3.85    |
| L6     | *Brake Band with Lining.....             | 5.35    |
| H6     | *Brake Band with Lining.....             | 6.95    |
| L7     | *Band Pin with Cotters.....              | .90     |
| H7     | *Band Pin with Nut.....                  | 1.10    |
| L8     | *Tension Pin with Cotters.....           | .65     |
| H8     | *Tension Pin with Cotters.....           | 1.00    |
| LH9    | *Eye Bolt Adjusting Screw with Nuts..... | .90     |
| H10    | *Eye Bolt Pin with Cotters.....          | .25     |
| H11    | *Pivot Pin with Cotters.....             | .40     |
| LH12   | *Collar Set Screw.....                   | .25     |
| L13    | *Brake Band Clamp.....                   | .50     |
| L14    | *Brake Band Lining.....                  | 1.35    |
| H14    | *Brake Band Lining.....                  | 1.85    |
| No. 44 | *Grease Cup.....                         | .60     |

Note this carefully when ordering parts

Parts numbers for pulleys having rims 12 in. and under in diameter are prefixed by the letter "L".

Parts numbers for pulleys having rims 16 in. and over in diameter are prefixed by the letter "H".

Parts that are interchangeable are prefixed by the letters "LH".

All items marked (\*) can be shipped by parcel post. All items marked (x) will be shipped by express or freight, collect.

## Biermann Friction Clutch Pulleys

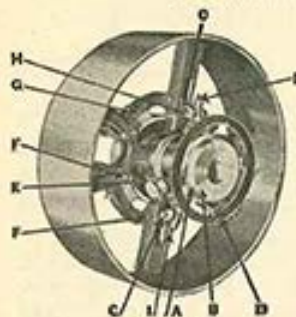

Figure 10

A friction clutch pulley is used in place of the solid pulley, so the engine may be started or stopped without having to throw off the belt, or the machine may be stopped without stopping the engine. This clutch has interchangeable rims, which can be easily removed so by purchasing one of these clutch pulleys with extra rims you will have an outfit that will run nearly every machine your engine can handle.

To change the pulley rims, loosen the four set screws "A" (Figure 10); remove the collar "B". Then take out the bolts "C" and remove the hand wheel and collar "D". Pull out the Friction Spider "E". Take out the cotter keys and drive out pins "F". This will free the friction blocks "G" and the adjusting arms "H". Your pulley is now completely dismantled. To build up the new pulley, take the new rim and simply reverse these operations.

The pulley is very easily adjusted by means of the adjusting bolts "I", but be sure to adjust them evenly so the bearing will be the same on all the blocks.

The pulley will stand still when the hand wheel "D" is pushed in. To start the machine pull the hand wheel "D" out slowly as this throws the load on the pulley gradually and will lengthen the life of your pulley.

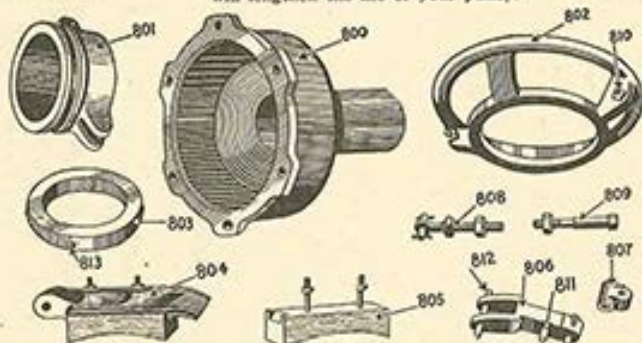

## Clutch Pulley Parts

Watch carefully to be sure you are giving us the correct diameter and face of pulley rim when ordering parts.

| No. | Description                      | PRICES                  |                                  | PRICES                     |                            | PRICES                     |                            |
|-----|----------------------------------|-------------------------|----------------------------------|----------------------------|----------------------------|----------------------------|----------------------------|
|     |                                  | For 8x6 F C Pulley Only | For 12 and 16x6 F C Pulleys Only | For all 8-in. Face Pulleys | For all 8-in. Face Pulleys | For all 8-in. Face Pulleys | For all 8-in. Face Pulleys |
| 800 | *Friction Spider.....            | \$4.50                  | \$9.85                           | \$13.20                    |                            |                            |                            |
| 801 | *Sliding Sleeve.....             | 3.40                    | 3.90                             | 5.15                       |                            |                            |                            |
| 802 | *Hand Wheel.....                 | 1.60                    | 1.85                             | 2.25                       |                            |                            |                            |
| 803 | *Friction Collar.....            | 1.00                    | 1.30                             | 1.95                       |                            |                            |                            |
| 804 | *Brake Shoe with Block.....      | 1.00                    | 1.30                             | 2.00                       |                            |                            |                            |
| 805 | *Friction Block.....             | .30                     | .40                              | .50                        |                            |                            |                            |
| 806 | *Adjusting Arm.....              | 1.00                    | 1.00                             | 1.30                       |                            |                            |                            |
| 807 | *Knuckle Joint.....              | .60                     | .60                              | .60                        |                            |                            |                            |
| 808 | *Adjusting Eye Bolt.....         | .65                     | .65                              | .90                        |                            |                            |                            |
| 809 | *Bolt or Brake Shoe.....         | .60                     | .70                              | .80                        |                            |                            |                            |
| 810 | *Bolt or Hand Wheel.....         | .10                     | .10                              | .10                        |                            |                            |                            |
| 811 | *Adjusting Arm Pin (short).....  | .20                     | .20                              | .20                        |                            |                            |                            |
| 812 | *Adjusting Arm Pin (long).....   | .20                     | .20                              | .20                        |                            |                            |                            |
| 813 | *Friction Collar Set Screws..... | .08                     | .08                              | .08                        |                            |                            |                            |

PRICES SUBJECT TO CHANGE WITHOUT NOTICE

Clutch Pulley Rims Only

| Size    | Price   | Size    | Price   | Size    | Price   |
|---------|---------|---------|---------|---------|---------|
| * 8 x 6 | \$ 7.00 | *16 x 6 | \$13.00 | *24 x 8 | \$19.00 |
| *12 x 6 | \$10.50 | *20 x 8 | \$16.50 | *28 x 8 | \$21.75 |

Six-inch Face Pulleys Must Not be Used on 9 or 12 Horse Power Engines  
Note--All items marked (\*) can be shipped by parcel post. All items marked (x) will be shipped by express or freight, collect.

## Price List of Kerosene Engine Parts Only

SUBJECT TO CHANGE WITHOUT NOTICE

When Ordering Parts, be Sure to Give the Letters, Numbers and Horse Power of Your Engine as Stamped on Name Plate

| PART No. | Description                                      | Old Rating | New Rating | Horse Power |       |        |        |        |        |        |        |        |        |        |
|----------|--------------------------------------------------|------------|------------|-------------|-------|--------|--------|--------|--------|--------|--------|--------|--------|--------|
|          |                                                  |            |            | 1 1/2       | 2 1/2 | 3      | 5      | 7      | 9      | 10     | 12     |        |        |        |
| Y12      | *Screw.....                                      |            |            |             |       | \$ .05 | \$ .05 | \$ .05 | \$ .05 | \$ .05 | \$ .05 | \$ .05 | \$ .05 | \$ .05 |
| K78      | *Pump Drive Pin.....                             |            |            |             |       | .08    | .08    | .08    | .08    | .08    | .08    | .08    | .08    | .08    |
| Y80      | *Cotter Pin.....                                 |            |            |             |       | .03    | .03    | .03    | .03    | .03    | .03    | .03    | .03    | .03    |
| Y84      | *Cotter Pin.....                                 |            |            |             |       | .03    | .03    | .03    | .03    | .03    | .03    | .03    | .03    | .03    |
| Y110     | *Locknut.....                                    |            |            |             |       | .05    | .05    | .05    | .05    | .05    | .05    | .05    | .05    | .05    |
| Y115     | *Nut.....                                        |            |            |             |       | .05    | .05    | .05    | .05    | .05    | .05    | .05    | .05    | .05    |
| Y145     | *Washer.....                                     |            |            |             |       | .05    | .05    | .05    | .05    | .05    | .05    | .05    | .05    | .05    |
| Y183     | *Gov. Shaft Arm Set Screw.....                   |            |            |             |       | .08    | .08    | .08    | .08    | .08    | .08    | .08    | .08    | .08    |
| Y196     | *Speed Change Lever Pin.....                     |            |            |             |       | .10    | .10    | .10    | .10    | .10    | .10    | .10    | .10    | .10    |
| 040      | *Taper Pin.....                                  |            |            | .05         | .05   | .05    | .05    | .05    | .05    | .05    | .05    | .05    | .05    | .05    |
| 0103     | *Pipe Plug.....                                  |            |            | .05         | .05   | .05    | .05    | .05    | .05    | .05    | .05    | .05    | .05    | .05    |
| 0104     | *Governor Shaft Arm Grease Cup.....              |            | .15        | .15         | .15   | .15    | .15    | .15    | .15    | .15    | .15    | .15    | .15    | .15    |
| 0152     | *Drain Valve.....                                |            |            | .45         | .45   | .45    | .45    | .45    | .45    | .45    | .45    | .45    | .45    | .45    |
| 0153     | *Fuel Valve, Kerosene Side.....                  | .30        | .30        | .30         | .30   | .30    | .30    | .30    | .30    | .30    | .30    | .30    | .30    | .30    |
| 0153A    | *Fuel Valve, Gasoline Side.....                  | .30        | .30        | .30         | .30   | .30    | .30    | .30    | .30    | .30    | .30    | .30    | .30    | .30    |
| 0154B    | *Governor Shaft Arm.....                         | .75        | .75        | .85         | .85   | .85    | .85    | .85    | .85    | .85    | .85    | .85    | .85    | .85    |
| 0155     | *Governor Shaft Bearing.....                     |            |            | .40         | .40   | .40    | .40    | .40    | .40    | .40    | .40    | .40    | .40    | .40    |
| 0156     | *Throttle Lever.....                             |            |            | .38         | .38   | .38    | .38    | .38    | .38    | .38    | .38    | .38    | .38    | .38    |
| 0157     | *Speed Changing Lever.....                       |            |            | .14         | .14   | .14    | .14    | .14    | .14    | .14    | .14    | .14    | .14    | .14    |
| 0158     | *Pump Body.....                                  |            |            | 1.43        | 1.43  | 1.43   | 1.43   | 1.43   | 1.43   | 1.43   | 1.43   | 1.43   | 1.43   | 1.43   |
| 0159     | *Pump Plunger.....                               |            |            | .67         | .67   | .67    | .67    | .67    | .67    | .67    | .67    | .67    | .67    | .67    |
| 0160     | *Check Ball.....                                 |            |            | .05         | .05   | .05    | .05    | .05    | .05    | .05    | .05    | .05    | .05    | .05    |
| 0161     | *Check Ball Retainer Pin.....                    |            |            | .05         | .05   | .05    | .05    | .05    | .05    | .05    | .05    | .05    | .05    | .05    |
| 0162     | *Pump Spring.....                                |            |            | .09         | .09   | .09    | .09    | .09    | .09    | .09    | .09    | .09    | .09    | .09    |
| 0164     | *Water Valve Seat.....                           |            |            | .38         | .38   | .38    | .38    | .38    | .38    | .38    | .38    | .38    | .38    | .38    |
| 0165     | *Water Valve.....                                |            |            | .30         | .30   | .30    | .30    | .30    | .30    | .30    | .30    | .30    | .30    | .30    |
| 0166     | *Fuel Valve Tee.....                             |            |            | .38         | .38   | .38    | .38    | .38    | .38    | .38    | .38    | .38    | .38    | .38    |
| 0167     | *Damper Lever.....                               | .12        | .12        | .12         | .12   | .12    | .12    | .12    | .12    | .12    | .12    | .12    | .12    | .12    |
| 0168     | *Pump Lever Pin.....                             |            |            | .10         | .10   | .10    | .10    | .10    | .10    | .10    | .10    | .10    | .10    | .10    |
| 0169     | *Butterfly Damper Spring.....                    | .10        | .10        | .08         | .08   | .08    | .08    | .08    | .08    | .08    | .08    | .08    | .08    | .08    |
| 0170     | *Speed Change Lever Spring.....                  |            |            | .08         | .08   | .08    | .08    | .08    | .08    | .08    | .08    | .08    | .08    | .08    |
| 0171     | *Carburetor Lid Flat Type.....                   |            |            | .05         | .05   | .05    | .05    | .05    | .05    | .05    | .05    | .05    | .05    | .05    |
| 0171A    | *Carburetor Lid and Pin.....                     | .10        | .10        | .10         | .10   | .10    | .10    | .10    | .10    | .10    | .10    | .10    | .10    | .10    |
| 0175     | *Pump Complete.....                              |            |            | 2.30        | 2.30  | 2.30   | 2.30   | 2.30   | 2.30   | 2.30   | 2.30   | 2.30   | 2.30   | 2.30   |
| 0176     | *Governor complete.....                          | 5.00       | 5.50       | 7.00        | 7.00  | 7.00   | 7.00   | 7.00   | 7.00   | 7.00   | 7.00   | 7.00   | 7.00   | 7.00   |
| 165      | *Carburetor Body.....                            | 3.00       | 3.00       | 3.45        | 3.45  | 3.45   | 3.45   | 3.45   | 3.45   | 3.45   | 3.45   | 3.45   | 3.45   | 3.45   |
| 165A     | *Kerosene Carburetor complete.....               | 5.00       | 5.00       | 9.00        | 9.00  | 9.00   | 9.00   | 9.00   | 9.00   | 9.00   | 9.00   | 9.00   | 9.00   | 9.00   |
| 166      | *Nozzle Tube.....                                |            |            | .08         | .08   | .08    | .08    | .08    | .08    | .08    | .08    | .08    | .08    | .08    |
| 167      | *Pump Lever.....                                 |            |            | .83         | .83   | .90    | .90    | .90    | .90    | .90    | .90    | .90    | .90    | .90    |
| 168      | *Air Damper Cage, with damper and stem.....      | 3.00       | 3.00       | 3.20        | 3.20  | 3.25   | 3.45   | 3.45   | 3.45   | 3.45   | 3.45   | 3.45   | 3.45   | 3.45   |
| 171      | xCylinder Head with Valves and Springs only..... | 6.10       | 6.35       | 9.85        | 12.95 | 14.60  | 17.70  | 20.20  | 20.20  | 20.20  | 20.20  | 20.20  | 20.20  | 20.20  |
| 172      | *Governor Shaft.....                             | .55        | .55        | .38         | .45   | .53    | .60    | .68    | .68    | .68    | .68    | .68    | .68    | .68    |
| 173      | *Air Damper Rod.....                             | .25        | .25        | .25         | .25   | .25    | .25    | .25    | .25    | .25    | .25    | .25    | .25    | .25    |
| 174      | *Carburetor Stud.....                            |            |            | .27         | .27   | .27    | .30    | .30    | .30    | .30    | .30    | .30    | .30    | .30    |
| 175      | *Fuel or Drain Pipe with Connect.....            |            |            | .70         | .77   | .82    | .86    | .93    | .93    | .93    | .93    | .93    | .93    | .93    |
| 176      | *Water Pipe.....                                 |            |            | .55         | .55   | .58    | .60    | .60    | .60    | .60    | .60    | .60    | .60    | .60    |
| 177      | *Cam Rod.....                                    | 1.25       | 1.25       | 1.43        | 1.65  | 1.88   | 2.18   | 2.55   | 2.55   | 2.55   | 2.55   | 2.55   | 2.55   | 2.55   |
| 178      | *Air Damper Cage Gasket.....                     | .15        | .15        | .15         | .15   | .15    | .15    | .15    | .15    | .15    | .15    | .15    | .15    | .15    |
| 179      | xKerosene Cylinder Head, comp.....               | 6.50       | 7.00       | 10.60       | 13.80 | 15.60  | 18.70  | 21.15  | 21.15  | 21.15  | 21.15  | 21.15  | 21.15  | 21.15  |
| 180      | *Exhaust Valve Spring (Kerosene Engine).....     | .15        | .15        | .15         | .15   | .23    | .30    | .30    | .30    | .30    | .30    | .30    | .30    | .30    |
| 184      | *Intake Valve Spring (Kerosene Engine).....      | .15        | .15        | .15         | .15   | .23    | .23    | .23    | .23    | .23    | .23    | .23    | .23    | .23    |

Note--All items marked (\*) can be shipped by parcel post. All items marked (x) will be shipped by express or freight, collect.

## Price List of Kerosene Engine Parts Only—Cont'd

SUBJECT TO CHANGE WITHOUT NOTICE

When Ordering Parts, be Sure to Give the Letters, Number and Horse Power of Your Engine as Stamped on Name Plate

| PART No. | Description                      | Old Rating<br>New Rating | Horse Power    |                |            |        |        |         |          |  |
|----------|----------------------------------|--------------------------|----------------|----------------|------------|--------|--------|---------|----------|--|
|          |                                  |                          | 1 1/2<br>1 3/4 | 2 1/2<br>2 3/4 | 3<br>3 1/2 | 5<br>6 | 7<br>8 | 9<br>10 | 12<br>14 |  |
| 12K      | *Cylinder Head Stud and Nut      | \$.30                    |                |                |            |        |        |         |          |  |
| 19K      | *Exhaust or Inlet Valve          | .40                      |                |                |            |        |        |         |          |  |
| 156K     | *Cam Gear                        | 2.50                     | \$2.50         |                |            |        |        |         |          |  |
| 1228K    | *Air Damper Plate                | .45                      | .45            |                |            |        |        |         |          |  |
| 1229K    | *Air Damper Disc                 | .05                      | .05            |                |            |        |        |         |          |  |
| 1230K    | *Air Damper Stem                 | .15                      | .15            |                |            |        |        |         |          |  |
| 1231K    | *Air Damper Spring               | .15                      | .15            |                |            |        |        |         |          |  |
| 1239K    | *Carburetor Gasket               | .15                      | .15            |                |            |        |        |         |          |  |
| 1K       | xBase                            | 20.50                    | 23.50          |                |            |        |        |         |          |  |
| Y577     | *Carburetor Set Screw            | .08                      | .05            |                |            |        |        |         |          |  |
| Y587     | *Carburetor Set Screw (Sp. Head) | .05                      | .05            |                |            |        |        |         |          |  |
| 17A      | *Cylinder Head Gasket            | .53                      | .53            |                |            |        |        |         |          |  |

For gasoline engine see No. 17, page 27.

## These Parts Used on Gasoline Engine Only

|      |                                                            |       |       |       |       |       |       |       |       |
|------|------------------------------------------------------------|-------|-------|-------|-------|-------|-------|-------|-------|
| 014  | *Straight Valve Cage and Check Valve                       | \$.60 | \$.60 | \$.60 | \$.60 | \$.60 | \$.60 | \$.60 | \$.60 |
| 016  | *Pipe Tee                                                  | .20   | .20   | .20   | .20   | .20   | .20   | .20   | .20   |
| 052  | *Detent Blade Adjusting Screw                              | .12   | .12   | .12   | .12   | .12   | .12   | .12   | .12   |
| 054  | *Detent Catch Block                                        | .30   | .30   | .30   | .30   | .30   | .30   | .30   | .30   |
| 055  | *Catch Block Screw                                         | .08   | .08   | .08   | .08   | .08   | .08   | .08   | .08   |
| 060  | *Governor, complete                                        | 5.30  | 6.00  | 8.00  | 8.00  | 8.00  | 8.00  | 8.00  | 8.00  |
| 076  | *Detent Blade                                              | .15   | .15   | .20   | .20   | .20   | .20   | .20   | .20   |
| 077  | *Detent Locknut, complete                                  | .15   | .15   | .15   | .15   | .15   | .15   | .15   | .15   |
| 0110 | *Speed Change Body                                         | .35   | .35   | .45   | .45   | .45   | .45   | .45   | .45   |
| 0111 | *Detent Lever                                              | .35   | .35   | .35   | .35   | .35   | .35   | .35   | .35   |
| 0112 | *Speed Change Lever                                        | .10   | .10   | .10   | .10   | .10   | .10   | .10   | .10   |
| 0113 | *Speed Lever Screw                                         | .05   | .05   | .05   | .05   | .05   | .05   | .05   | .05   |
| 0133 | *Fuel Valve                                                | .30   | .30   | .30   | .30   | .30   | .30   | .30   | .30   |
| 0136 | *Damper Screw                                              | .05   | .05   | .05   | .05   | .05   | .05   | .05   | .05   |
| 0142 | *Detent Spring                                             | .09   | .09   | .09   | .09   | .09   | .09   | .09   | .09   |
| 18A  | xCylinder Head, complete with Valves Springs, Levers, etc. | 5.00  | 7.00  | 9.85  | 12.95 | 14.65 | 17.75 | 19.90 |       |
| 18   | xCylinder Head with Valves and Springs only                | 4.45  | 6.35  | 9.00  | 12.10 | 13.75 | 16.80 | 19.00 |       |
| 22   | *Exhaust Valve Spring                                      | .15   | .15   | .15   | .15   | .23   | .23   | .25   |       |
| 23   | *Inlet Valve Spring                                        | .15   | .15   | .15   | .15   | .25   | .25   | .25   |       |
| 35   | *Gasoline Mixing Valve, complete                           | 2.75  | 2.90  | 2.90  | 3.15  | 3.70  | 4.00  | 4.65  |       |
| 38   | *Supply Pipe and Connectors                                | .52   | .52   | .60   | .60   | .65   | .71   | .89   |       |
| 45   | *Cam Rod                                                   | 1.35  | 1.35  | 1.50  | 1.60  | 1.65  | 1.85  | 2.15  |       |
| 48A  | *Cam Rod with Roller and Catch Block                       | 1.60  | 1.60  | 2.00  | 2.10  | 2.25  | 2.37  | 2.50  |       |
| 124  | *Mixing Valve Body                                         | 1.35  | 1.50  | 1.50  | 1.75  | 2.30  | 2.60  | 3.10  |       |
| 125  | *Mixing Valve Damper                                       | .21   | .21   | .21   | .21   | .26   | .26   | .26   |       |

Note—All items marked (\*) can be shipped by parcel post. All items marked (x) will be shipped by express or freight, collect.

## Price List of Engine Parts that Can be Used on Either Gasoline or Kerosene Engines

SUBJECT TO CHANGE WITHOUT NOTICE

When Ordering Parts, be Sure to Give the Letters, Number and Horse Power of Your Engine as Stamped on Name Plate

| PART No. | Description                                                                 | Old Rating<br>New Rating | Horse Power    |                |            |         |         |         |          |  |
|----------|-----------------------------------------------------------------------------|--------------------------|----------------|----------------|------------|---------|---------|---------|----------|--|
|          |                                                                             |                          | 1 1/2<br>1 3/4 | 2 1/2<br>2 3/4 | 3<br>3 1/2 | 5<br>6  | 7<br>8  | 9<br>10 | 12<br>14 |  |
| 1        | *Base (Stationary)                                                          | \$20.50                  | \$23.50        | \$17.75        | \$26.65    | \$40.75 | \$58.00 | \$79.25 |          |  |
| 2        | *Base Cap                                                                   | .70                      | .85            | 1.25           | 1.65       | 1.90    | 2.45    | 2.65    |          |  |
| 4        | *Main Bearing Grease Cup                                                    | .12                      | .12            | .15            | .18        | .18     | .25     | .25     |          |  |
| 5        | *Base Cap Stud and Nuts                                                     | .30                      | .35            | .35            | .35        | .50     | .50     | .50     |          |  |
| 6        | *Bearing Liner, thick, per set                                              | .15                      | .20            | .23            | .23        | .23     | .23     | .25     |          |  |
| 7        | *Bearing Liners, thin, per set                                              |                          |                | .23            | .25        | .27     | .27     | .27     |          |  |
| 8        | *Main Bearings (two halves)                                                 | 1.20                     | 1.30           | 1.55           | 2.35       | 3.80    | 4.25    | 5.40    |          |  |
| 9        | xCylinder                                                                   |                          |                | 12.75          | 17.00      | 23.25   | 33.90   | 44.00   |          |  |
| 11       | *Cylinder Cap Screw                                                         |                          |                | .15            | .15        | .20     | .20     | .20     |          |  |
| 12       | *Cylinder Head Stud and Nut                                                 | .35                      | .45            | .45            | .45        | .60     | .70     | .70     |          |  |
| 13       | *Sight Feed Oiler, complete                                                 | 1.95                     | 1.95           | 2.10           | 2.10       | 2.40    | 2.75    | 2.75    |          |  |
| 13A      | *Large Glass for Oiler                                                      | .45                      | .45            | .53            | .53        | .60     | .65     | .68     |          |  |
| 13B      | *Small Glass for Oiler                                                      | .30                      | .30            | .30            | .30        | .30     | .30     | .30     |          |  |
| 13C      | *Small Glass Cage                                                           | .30                      | .30            | .30            | .30        | .30     | .30     | .30     |          |  |
| 13D      | *Cap for Oiler                                                              | .60                      | .60            | .60            | .60        | .70     | .70     | .70     |          |  |
| 14       | *Oiler Pipe                                                                 | .27                      | .27            | .27            | .27        | .30     | .38     | .38     |          |  |
| 15       | xWater Reservoir                                                            |                          |                | 6.85           | 9.70       | 14.55   | 15.80   | 23.50   |          |  |
| Y15      | *Oil Guard Cap Screw with Washer                                            | .10                      | .10            | .10            | .10        | .10     | .10     | .10     |          |  |
| 16       | *Water Reservoir Gasket                                                     |                          |                | .25            | .30        | .35     | .65     | .75     |          |  |
| 17       | *Cylinder Head Gasket                                                       | .53                      | .55            | .55            | .80        | 1.13    | 1.43    | 1.88    |          |  |
| 19       | *Exhaust or Inlet Valve                                                     | .40                      | .40            | .65            | .85        | 1.00    | 1.25    | 1.55    |          |  |
| 24       | *Valve Lock Lever                                                           | .15                      | .15            | .15            | .15        | .15     | .23     | .23     |          |  |
| 25       | *Valve Lock Stud                                                            |                          |                | .15            | .15        | .15     | .15     | .15     |          |  |
| 26       | *Valve Lock Spring                                                          |                          |                | .12            | .12        | .14     | .14     | .14     |          |  |
| 27       | *Pipe Plug                                                                  | .05                      | .05            | .05            | .05        | .05     | .05     | .05     |          |  |
| 28       | *Valve Lever                                                                | .45                      | .50            | .53            | .60        | .68     | .75     | .90     |          |  |
| 29       | *Valve Lever Pin                                                            | .12                      | .12            | .15            | .15        | .24     | .24     | .24     |          |  |
| 30       | *Street Elbow                                                               | .25                      | .40            | .90            | .90        | 1.50    | 2.00    |         |          |  |
| 31       | *Muffler Body with Nipple                                                   | 1.00                     | 1.65           | 2.03           | 2.33       | 2.85    | 3.75    |         |          |  |
| 32       | *Muffler Complete with Nipple                                               | 1.88                     | 1.88           | 2.78           | 3.38       | 3.68    | 4.88    | 6.00    |          |  |
| 33       | *Muffler Cap                                                                | .60                      | .60            | 1.13           | 1.35       | 1.35    | 2.03    | 2.03    |          |  |
| 37       | *Oil Guard                                                                  | 1.50                     | 1.50           | 1.80           | 2.25       | 2.50    | 3.10    | 4.25    |          |  |
| 40       | *Strainer Nipple                                                            | .60                      | .60            | .60            | .60        | .60     | .60     | .60     |          |  |
| 42       | *Fuel Tank                                                                  | 2.25                     | 2.45           | 2.80           | 3.55       | 3.70    | 4.45    | 5.00    |          |  |
| 47       | *Stationary Tank Binders with Nuts                                          | .25                      | .25            | .35            | .30        | .30     | .35     | .35     |          |  |
| 49       | *Cam Gear                                                                   | 2.25                     | 2.25           | 3.75           | 3.75       | 5.90    | 6.10    | 6.35    |          |  |
| 52       | *Cam Gear Stud, complete                                                    | .15                      | .75            | 1.50           | 1.50       | 1.75    | 1.75    | 1.75    |          |  |
| Y487     | *Cam Gear Oil Pipe with Coupling                                            |                          |                | .25            | .25        | .25     | .25     | .25     |          |  |
| 53       | *Crankshaft Pinion                                                          | 1.00                     | 1.05           | 1.85           | 1.85       | 2.05    | 2.05    | 2.05    |          |  |
| 54       | *Crankshaft Pinion Key                                                      | .09                      | .09            | .09            | .12        | .12     | .12     | .12     |          |  |
| 55       | xCrankshaft                                                                 | 6.00                     | 7.25           | 9.50           | 14.25      | 17.00   | 20.00   | 26.00   |          |  |
| 56       | *Connecting Rod and Cap (with bolts and nuts. Cap not furnished separately) | 4.50                     | 5.60           | 7.50           | 9.75       | 11.75   | 15.00   | 18.50   |          |  |
| 56A      | *Connecting Rod Complete (with bearings)                                    | 5.40                     | 6.60           | 8.55           | 11.35      | 13.95   | 17.50   | 22.50   |          |  |
| 56C      | *Connecting Rod Cap only                                                    | .70                      |                |                |            |         |         |         |          |  |
| 57       | *Connecting Rod Bushing                                                     | .45                      | .60            | .90            | 1.20       | 1.30    | 1.70    | 2.10    |          |  |
| 58       | *Connecting Rod Bearing (2 halves)                                          | .98                      | 1.10           | 1.15           | 1.75       | 2.30    | 2.80    | 3.75    |          |  |
| 59       | *Connecting Rod Bolt with Cotter Pin and Nut                                | .30                      | .35            | .55            | .55        | .75     | .85     | .90     |          |  |
| 59 1/2   | *Connecting Rod Nut                                                         | .06                      | .06            | .06            | .06        | .06     | .09     | .09     |          |  |
| 60       | *Connecting Rod Liners, thick, per set                                      | .15                      | .15            | .23            | .23        | .23     | .23     | .23     |          |  |
| 61       | *Connecting Rod Liners, thin, per set                                       | .15                      | .15            | .23            | .23        | .23     | .23     | .23     |          |  |
| 63       | *Connecting Rod Grease Cup                                                  | .38                      | .38            | .75            | .95        | 1.15    | 1.15    | 1.15    |          |  |

Note—All items marked (\*) can be shipped by parcel post. All items marked (x) will be shipped by express or freight, collect.

## Price List of Engine Parts that can be Used on Either Gasoline or Kerosene Engines

SUBJECT TO CHANGE WITHOUT NOTICE

When Ordering Parts, be Sure to Give the Letters, Number and Horse Power  
of Your Engine as Stamped on Name Plate

| PART No. | Description                                    | Old Rating | Horse Power |        |        |        |        |        |         |     |   |   |   |    |    |    |
|----------|------------------------------------------------|------------|-------------|--------|--------|--------|--------|--------|---------|-----|---|---|---|----|----|----|
|          |                                                |            | New Rating  | 1½     | 2½     | 3      | 3½     | 4      | 5       | 6   | 7 | 8 | 9 | 10 | 12 | 14 |
| 64       | Piston                                         |            | \$2.90      | \$3.60 | \$4.50 | \$5.60 | \$7.50 | \$8.50 | \$11.00 |     |   |   |   |    |    |    |
| 65       | *Piston Ring (each)                            |            | .38         | .40    | .45    | .60    | .68    | .75    | .98     |     |   |   |   |    |    |    |
| 66       | *Piston Pin                                    |            | .53         | .60    | .75    | .95    | 1.25   | 1.50   | 1.75    |     |   |   |   |    |    |    |
| 67       | *Piston Pin Set Screw complete                 |            | .09         | .09    | .09    | .09    | .15    | .15    | .15     |     |   |   |   |    |    |    |
| 68       | xFlywheel (each) with key                      |            | 6.25        | 8.25   | 12.00  | 19.50  | 27.75  | 45.00  | 61.00   |     |   |   |   |    |    |    |
| 70       | *Flywheel Key                                  |            | .12         | .12    | .12    | .15    | .15    | .23    | .23     |     |   |   |   |    |    |    |
| 71       | *Flywheel Bolt                                 |            | .25         | .25    | .25    | .25    | .25    | .38    | .38     |     |   |   |   |    |    |    |
| 77       | Starting Crank                                 |            | 1.00        | 1.00   | 1.50   | 1.50   | 1.60   |        |         |     |   |   |   |    |    |    |
| 77S      | Starter Crank (Socket Type)                    |            | 1.00        | 1.00   | 1.50   | 1.50   | 1.60   |        |         |     |   |   |   |    |    |    |
| 79       | *Machine Bolt for Pulley                       |            |             |        | .10    | .10    | .10    | .10    | .10     |     |   |   |   |    |    |    |
| 80       | *Pulley Stud with Nut                          |            | .10         | .10    |        |        |        |        |         |     |   |   |   |    |    |    |
| 81       | *Piston Oil Tube                               |            |             |        | .30    | .30    | .30    | .30    | .30     |     |   |   |   |    |    |    |
| 84       | xMounting Engine Fuel Tank                     |            |             |        |        |        | 7.50   | 8.25   | 8.25    |     |   |   |   |    |    |    |
| 89       | *Mounting Tank Binders                         |            |             |        |        |        |        | .33    | .60     | .60 |   |   |   |    |    |    |
| 01       | *Igniter Stud and Nut                          |            | .20         | .20    | .20    | .20    | .20    | .20    | .20     |     |   |   |   |    |    |    |
| 02       | *Drain Cock                                    |            | .50         | .50    | .50    | .50    | .50    | .50    | .50     |     |   |   |   |    |    |    |
| 04       | *Oil Pipe Coupling                             |            | .15         | .15    | .15    | .15    | .15    | .15    | .15     |     |   |   |   |    |    |    |
| 05       | *Water Reservoir Bolt                          |            | .10         | .10    | .10    | .10    | .10    | .10    | .10     |     |   |   |   |    |    |    |
| 06       | *Valve Lever Adjusting Screw and Nut           |            | .16         | .16    | .16    | .16    | .16    | .16    | .16     |     |   |   |   |    |    |    |
| 010      | *Angle Connection                              |            | .30         | .30    | .30    | .30    | .30    | .30    | .30     |     |   |   |   |    |    |    |
| 011      | *Straight Connection                           |            | .30         | .30    | .30    | .30    | .30    | .30    | .30     |     |   |   |   |    |    |    |
| 022      | *Tank Rod                                      |            | .15         | .15    | .23    | .23    | .23    | .23    | .23     |     |   |   |   |    |    |    |
| 023      | *Filler Pipe                                   |            | .38         | .38    | .57    | .57    | .57    | .57    | .57     |     |   |   |   |    |    |    |
| 026      | *Igniter Gasket                                |            | .15         | .15    | .15    | .15    | .15    | .15    | .15     |     |   |   |   |    |    |    |
| 056      | *Cam Roller                                    |            | .23         | .23    | .32    | .32    | .32    | .32    | .32     |     |   |   |   |    |    |    |
| 057      | *Cam Roller Pin with Dowel                     |            | .15         | .15    | .15    | .15    | .15    | .15    | .15     |     |   |   |   |    |    |    |
| 059      | *Cam Rod Spring                                |            | .12         | .12    | .12    | .12    | .12    | .12    | .12     |     |   |   |   |    |    |    |
| 062      | *Governor Spindle                              |            | .95         | .95    | 1.40   | 1.40   | 1.40   | 1.40   | 1.40    |     |   |   |   |    |    |    |
| 062A     | *Governor Spindle                              |            | .95         | .95    | 1.40   | 1.40   | 1.40   | 1.40   | 1.40    |     |   |   |   |    |    |    |
| 063      | *Governor Pinion with Set Screw                |            | .55         | .55    | .55    | .55    | .55    | .55    | .55     |     |   |   |   |    |    |    |
| 063½     | *Governor Pinion Set Screw                     |            | .05         | .05    | .05    | .05    | .05    | .05    | .05     |     |   |   |   |    |    |    |
| 064      | *Governor Ball                                 |            | .25         | .25    | .25    | .25    | .25    | .25    | .25     |     |   |   |   |    |    |    |
| 064B     | *Governor Ball                                 |            | .25         | .25    | .25    | .25    | .25    | .25    | .25     |     |   |   |   |    |    |    |
| 065      | *Governor Weight Pin with Cotter Pin           |            | .09         | .09    | .12    | .12    | .12    | .12    | .12     |     |   |   |   |    |    |    |
| 065A     | *Governor Weight Pin with Cotter Pin           |            | .09         | .09    | .12    | .12    | .12    | .12    | .12     |     |   |   |   |    |    |    |
| 066      | *Governor Bracket Plate                        |            |             |        | .20    | .20    | .20    | .20    | .20     |     |   |   |   |    |    |    |
| 067      | *Bracket Plate Screw                           |            |             |        | .12    | .12    | .12    | .12    | .12     |     |   |   |   |    |    |    |
| 068      | *Governor Spindle Rod                          |            | .25         | .40    | .40    | .40    | .40    | .40    | .40     |     |   |   |   |    |    |    |
| 068B     | *Governor Spindle Rod                          |            |             |        | .25    | .25    | .25    | .25    | .25     |     |   |   |   |    |    |    |
| 068C     | *Governor Spindle Rod End                      |            |             |        | .10    | .10    | .10    | .10    | .10     |     |   |   |   |    |    |    |
| 070      | *Speed Changing Washer                         |            | .08         | .08    | .08    | .08    | .08    | .08    | .08     |     |   |   |   |    |    |    |
| 075      | *Detent Lever Pin                              |            | .12         | .12    | .12    | .12    | .12    | .12    | .12     |     |   |   |   |    |    |    |
| 078      | *Governor Bracket Dowels                       |            | .09         | .09    | .09    | .09    | .09    | .09    | .09     |     |   |   |   |    |    |    |
| 079      | *Cap Screws                                    |            | .09         | .09    | .12    | .12    | .12    | .12    | .12     |     |   |   |   |    |    |    |
| 097      | *Igniter Wrench                                |            | .30         | .30    | .30    | .30    | .35    | .35    | .35     |     |   |   |   |    |    |    |
| 0195     | *Governor Thrust Washer                        |            | .15         | .15    | .15    | .15    | .15    | .15    | .15     |     |   |   |   |    |    |    |
| 0104     | *Governor Bracket Grease Cup                   |            | .15         | .15    | .15    | .15    | .15    | .15    | .15     |     |   |   |   |    |    |    |
| 0105     | *½-inch Drain Plug                             |            | .05         | .05    | .05    | .05    | .05    | .05    | .05     |     |   |   |   |    |    |    |
| 0114     | *Governor Bracket                              |            | 1.05        | 1.10   | 1.90   | 1.90   | 1.90   | 1.90   | 1.90    |     |   |   |   |    |    |    |
| 0137     | *Fuel Valve Spring                             |            | .08         | .08    | .08    | .08    | .08    | .08    | .08     |     |   |   |   |    |    |    |
| 0137A    | *Fuel Valve Spring                             |            | .08         | .08    | .08    | .08    | .08    | .08    | .08     |     |   |   |   |    |    |    |
| 0138     | *Governor Spindle Spring                       |            | .12         | .12    | .12    | .12    | .12    | .12    | .12     |     |   |   |   |    |    |    |
| Y111     | *Cam Rollers Stud Nut                          |            | .05         | .05    | .05    | .05    | .05    | .05    | .05     |     |   |   |   |    |    |    |
| Y167     | *Cam Gear Pin Set Screw, complete              |            | .10         |        |        |        |        |        |         |     |   |   |   |    |    |    |
| Y230     | *Oil Pipe Elbow                                |            |             |        | .18    | .18    | .18    | .18    | .18     |     |   |   |   |    |    |    |
| Y232     | *Oil Pipe (short nipple)                       |            |             |        | .10    | .10    | .10    | .10    | .10     |     |   |   |   |    |    |    |
| Y263     | *Oil Pipe Support                              |            |             |        | .10    | .10    | .10    | .10    | .10     |     |   |   |   |    |    |    |
| Y306     | *Steel Ball 3½ to 14                           |            |             |        | .05    | .05    | .05    | .05    | .05     |     |   |   |   |    |    |    |
| Y467     | *Set Screw with Lock Nut                       |            | .05         | .05    | .05    | .05    | .05    | .05    | .05     |     |   |   |   |    |    |    |
| Y104     | *Governor Bracket Grease Cup Nipple with Union |            | .15         |        |        |        |        |        |         |     |   |   |   |    |    |    |

Note—All items marked (\*) can be shipped by parcel post. All items marked (x) will be shipped by express or freight, collect.

## Help Us to Help You!

Read this page carefully before  
ordering any repair parts

The following information which you will find stamped on the name plate must be given in your orders for repair parts before we can fill them:

The number and quantity of parts wanted.

The engine number.

The horse power.

The letter appearing after horse power of engines.

If you fail to give us this information it will be necessary to delay your order and write you for same, therefore, to avoid annoying delays, see that the information requested above is given on every order for repair parts.

If you are ordering parts for a kerosene throttling governor engine see page 25; if for gasoline, see page 26; if you do not find the parts listed there, see pages 27 and 28, but be sure to give us the correct number.

For example: If you want a Cylinder Head complete for a kerosene throttling governor engine, write your order as follows:

Ship by (parcel post, express or freight) one No. 179 Cylinder Head Complete for a K-14S Engine, number 125387; or, if it is a gasoline engine, order one No. 18-A Cylinder Head Complete for a 14-S engine, number 123496.

## Help Us to Help You!



## How to Start and Care for Your Engine

"A large part of the success and service you get out of your engine depends upon the attention you give it the first few hours and days you use it."

Before starting your engine "OIL IT." Do not depend upon the oil cups and sight feed oilers for the first oiling, but take your oil can and oil each moving part. Move the working parts with your hands. See that each part is moving freely and that the oil is getting to the places where it is needed.

Turn your flywheels over until the piston comes out of the cylinder as far as it will come, then oil the end of the piston and the piston pin inside the piston.

Your engine is new and all parts are tight. The oil put on it at the factory immediately before shipping has dried and will have to be softened up before the oiling system will perform its regular duty.

Watch your engine carefully. Do not let it get too hot at first. Care for it carefully and it will last you for years.

A little time spent now will save both

"Time and Trouble afterwards."

HERCULES PRODUCTS, Inc.

"Too Much Fuel and Oil Sometimes Fouls Spark Plug"

## Kerosene Governor and Carburetor Parts for 1 $\frac{3}{4}$ and 2 $\frac{1}{2}$ Kerosene Engines

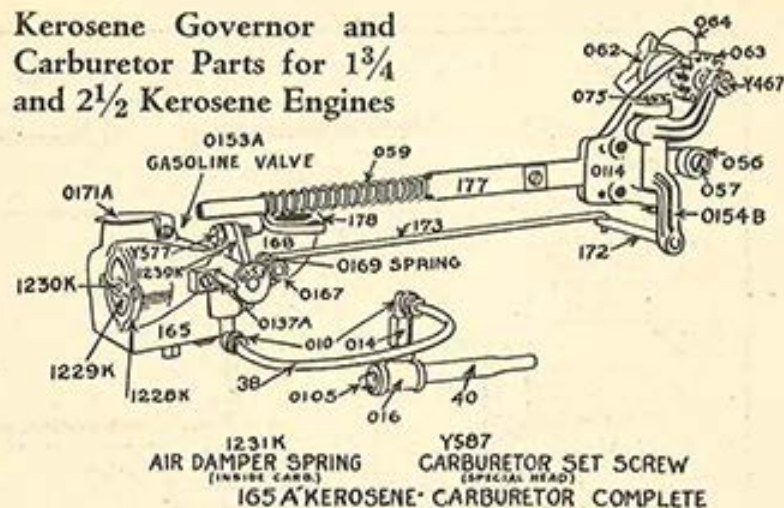

Figure 10

The word "spark" stamped on the face of the flywheel should pass the top edge of the valve rod "A" at the same time the magneto trips.

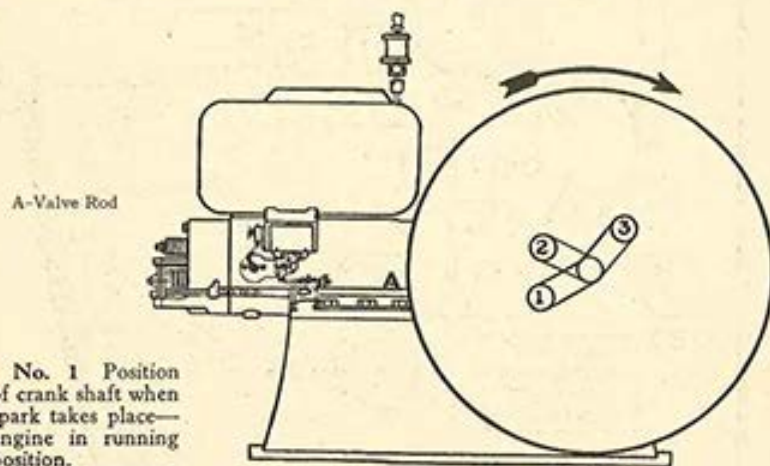
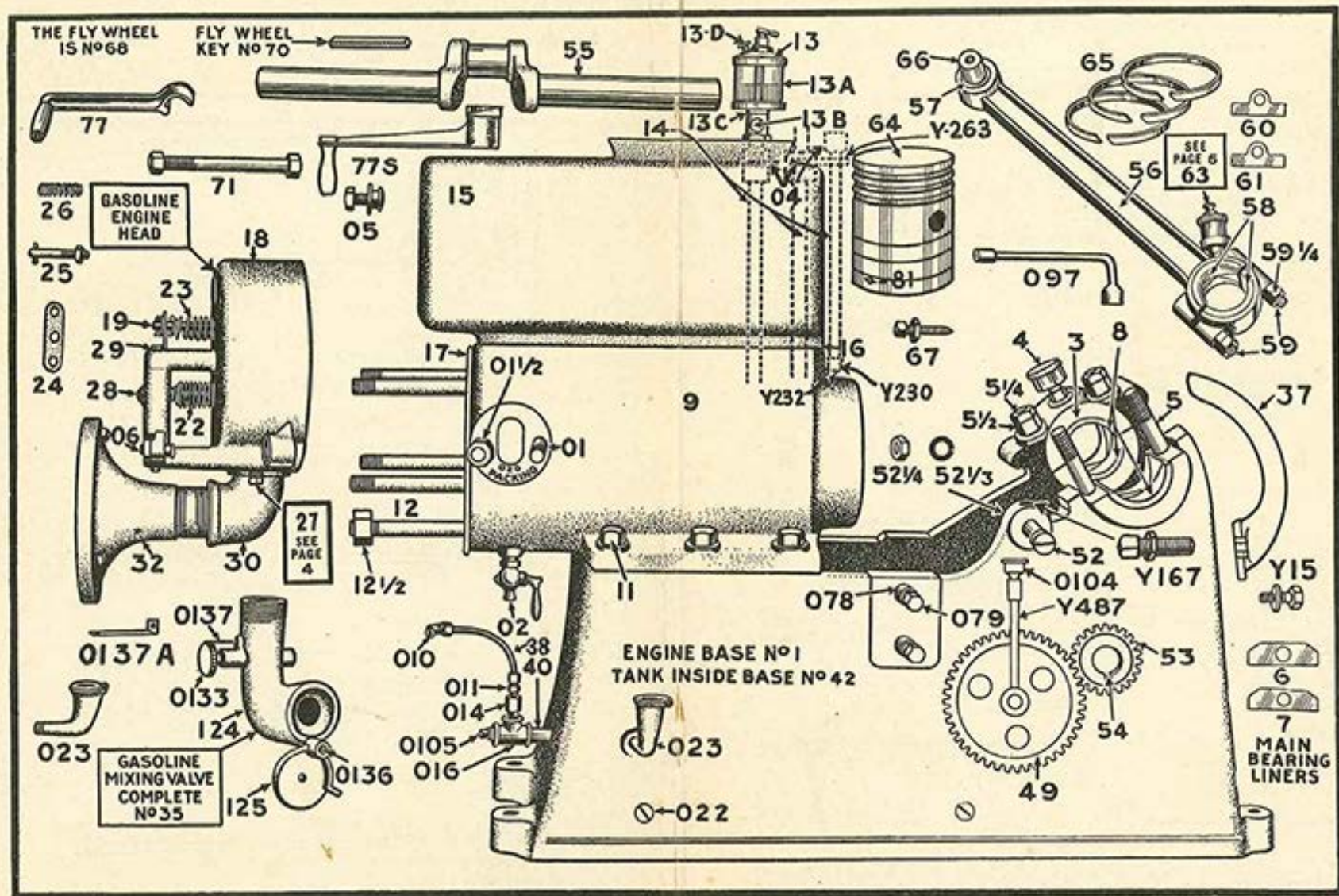

Figure 11

No. 1 Position of crank shaft when spark takes place—engine in running position.

No. 2 Position of crank shaft when exhaust valve closes.

No. 3 Position of crank shaft when exhaust valve opens.



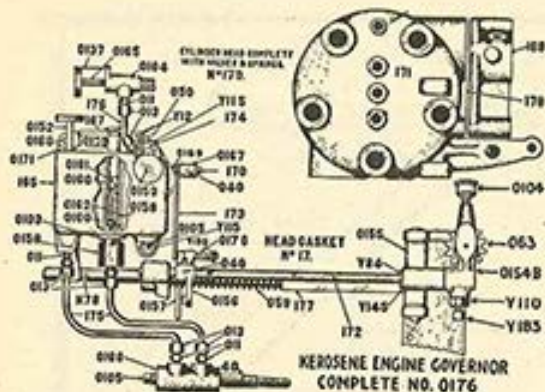

MODEL "H & S"  
GOVERNOR  
SPINDLE ROD

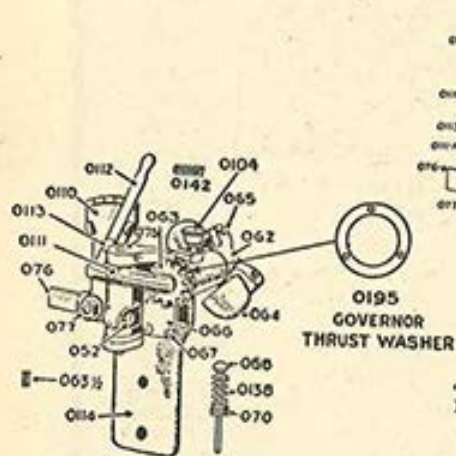

"Gasoline Engine Governor Complete  
for Models E, F and G Engines"

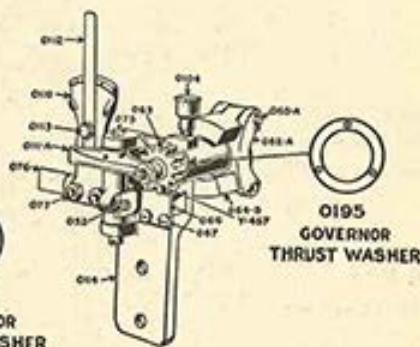

"Gasoline Engine Governor Complete For  
Models H and S Engines"

"These Complete Governors are Interchangeable on Models E-F-G-H and S 3 to 14 H. P. Engines"  
When You Order Complete Governors We Will Ship Improved Models H and S

## Direct Connected Vertical and Horizontal Pump Jack Parts

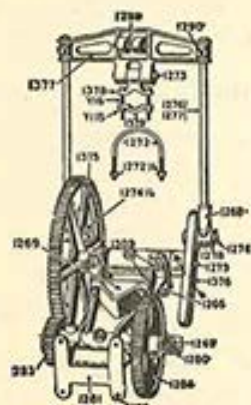

| Part No. | Description                                         | Price  |
|----------|-----------------------------------------------------|--------|
| 182      | *Cap Screw                                          | \$0.05 |
| 1266     | *Pump Gear Bearing and Bracket, Weight 12 lbs.      | 5.00   |
| 1268     | *Pump Rod Head with Pin (Special Size of Pump Rods) | .50    |
| 1269     | *Stand                                              | 1.40   |
| 1272     | *Vertical Pump Clamp                                | .20    |
| 1272 1/2 | *Nut for Clamp                                      | .05    |
| 1273     | *Pump Lever Pin                                     | .10    |
| 1274     | *Pump Rod Stud                                      | .25    |
| 1274 1/2 | *Nut for No. 1274                                   | .10    |
| 1275     | *Large Pump Gear Shaft                              | .75    |
| 1276     | *Horizontal Short Pump Rod                          | 1.10   |
| 1277     | *Vertical Long Pump Rod                             | 1.80   |
| 1278     | *Washer for Pump Rod Stud                           | .05    |
| 1280     | *Small Gear Shaft                                   | .75    |
| 1281     | *Engine End Bracket                                 | 2.25   |
| 1283     | *Pinion with Pin                                    | 2.35   |
| 1284     | *Gear with Pin, Weight 10 lbs.                      | 3.30   |
| 1288     | *Vertical Pump Rod Pin                              | .15    |
| 1290     | *Set Screws                                         | .05    |
| 1309     | *Bolt for Stand                                     | .05    |
| 1375     | *Crank Gear with Pin, Weight 17 lbs.                | 6.35   |
| 1376     | *Bell Crank with Pin                                | 1.65   |
| 1377     | *Crosshead                                          | 2.45   |
| 1378     | *Pump Handle Clamp                                  | .40    |
| 1379     | *Clamp Cap                                          | .25    |
| Y16      | *Cap Screw                                          | .10    |
| Y115     | *Nut                                                | .05    |

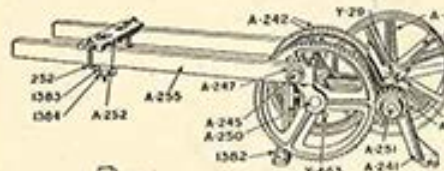

## Horizontal and Vertical Double Geared Belt Driven Pump Jack Parts

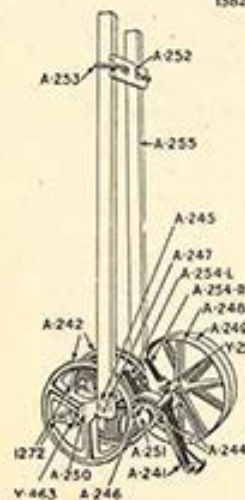

| Part No. | Description           | Price  |
|----------|-----------------------|--------|
| A-241    | Base                  | \$3.00 |
| A-242    | Crank Gear            | 1.90   |
| A-244    | Pinion                | .65    |
| A-248    | Pulley (Loose)        | 2.00   |
| A-249    | Pulley (Tight)        | 2.10   |
| A-252    | Cross Head            | .90    |
| A-254-R  | Gear Guard (Right)    | .30    |
| A-254-L  | Gear Guard (Left)     | .30    |
| A-243    | Spacing Collar        | .10    |
| 1382     | Stand                 | .80    |
| 1383     | Pump Handle Clamp     | .30    |
| 1384     | Pump Handle Clamp Cap | .25    |
| A-250    | Crank Gear Shaft      | .40    |
| A-251    | Pinion Shaft          | .65    |
| A-245    | Crank Pin             | .50    |
| A-246    | Pinion Pin            | .05    |
| A-253    | Cross Head Clamp      | .25    |
| 1385     | Pump Clamp Pin        | .10    |
| 1272     | Pump Clamp            | .30    |
| A-255    | Pump Arm              | .90    |
| A-247    | Crank Pin Washer      | .05    |
| Y-29     | Cap Screw             | .05    |
| Y-463    | Set Screw             | .05    |

NOTE—All items marked (\*) can be shipped by parcel post. All items marked (x) will be shipped by express or freight, collect.

## Wico Magneto

With Complete Equipment

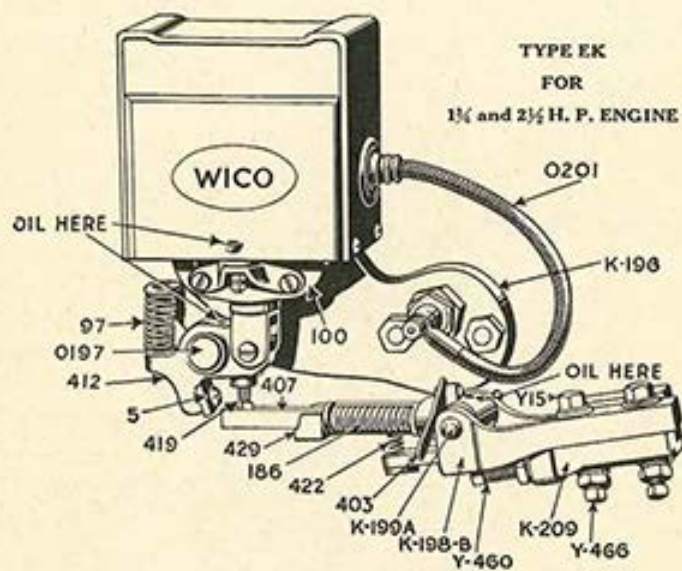

Figure 12

## Wico Magneto

With Complete Equipment

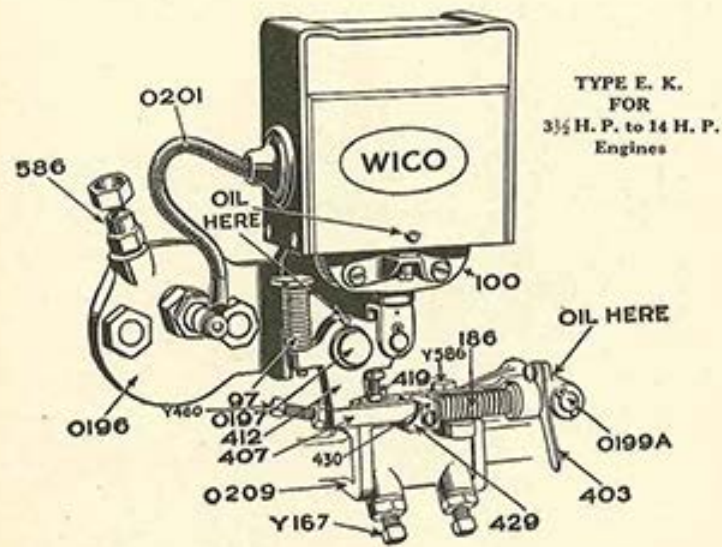

Figure 13

# Wico Magneto

With Complete Equipment

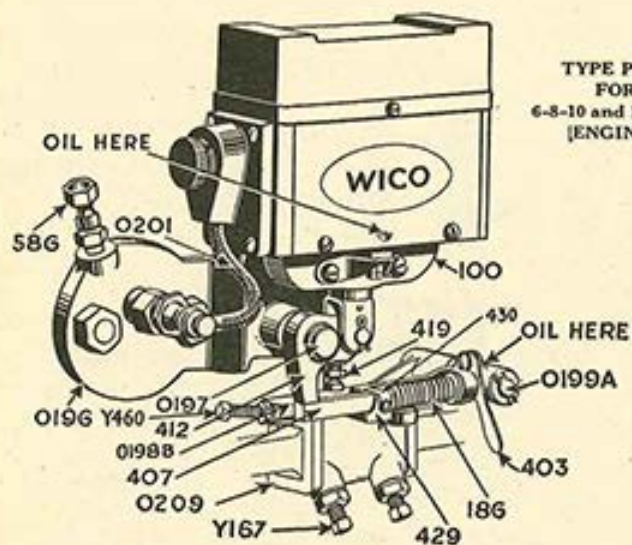
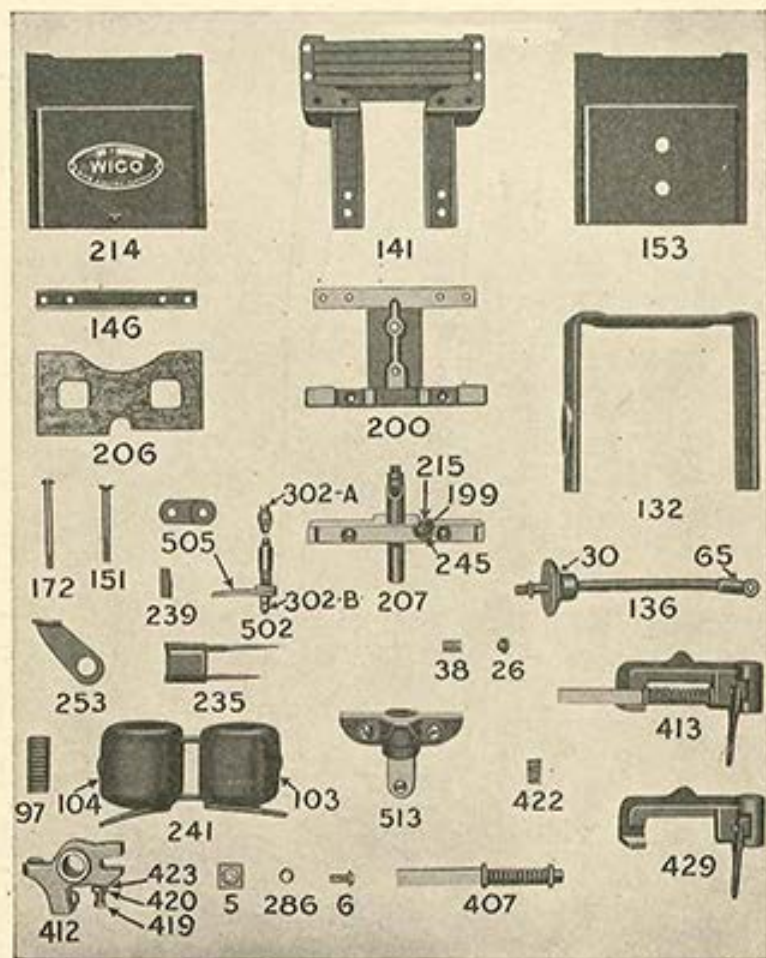

Figure 14

TYPE P. R.  
FOR  
6-8-10 and 14 H. P.  
ENGINES

## Parts and Numbers for the Wico Type E. K. Magneto as used on 1 $\frac{3}{4}$ H. P. to 14 H. P. Engines



To avoid delays and mistakes always show number, name of part and type of magneto. For prices see page 40.

## Parts Price List of Wico Type E. K. Magneto as used on 1<sup>3</sup>/<sub>4</sub> H. P. to 14 H. P. Engines

| Part No. | Name                                                                                                       | List Price |
|----------|------------------------------------------------------------------------------------------------------------|------------|
| W5       | Latch Block                                                                                                | .35        |
| W6       | Latch Block Screw                                                                                          | .05        |
| W26      | Spring Clamp Washer                                                                                        | .10        |
| W30      | Terminal Ins. Block                                                                                        | .30        |
| W38      | Terminal Contact Spring                                                                                    | .20        |
| W63      | Lead Wire Terminal                                                                                         | .05        |
| 97       | Armature Return Spring                                                                                     | .40        |
| 103      | Coil Group R. H.                                                                                           | 3.75       |
| 104      | Coil Group L. H.                                                                                           | 3.75       |
| 107      | Core Group                                                                                                 | 1.25       |
| 132      | Side Band Group                                                                                            | 1.00       |
| 136      | Terminal Group                                                                                             | 1.10       |
| 141      | Magnet Group                                                                                               | 6.50       |
| 146      | Cross Arm                                                                                                  | .10        |
| 151      | Deck Screw                                                                                                 | .10        |
| 153      | Back Cover                                                                                                 | .35        |
| W172     | Pole Yoke Screw                                                                                            | .10        |
| 186      | Latch Spring                                                                                               | .25        |
| 199      | Ground Connection Screw Side Band Screw                                                                    | .05        |
| 200      | Assembly Plate                                                                                             | 1.00       |
| 206      | Coil Gasket                                                                                                | .10        |
| 207      | Deck Half Group                                                                                            | 1.75       |
| 214      | Front Cover                                                                                                | .50        |
| 215      | Ground Connection Screw Lock Washer                                                                        | .05        |
| 235      | Condenser                                                                                                  | 3.00       |
| 239      | Coil Wedge                                                                                                 | .05        |
| 241      | Coil Group                                                                                                 | 8.00       |
| 245      | Ground Lead Clamp Washer                                                                                   | .05        |
| 253      | Return Spring Support                                                                                      | .10        |
| 286      | Latch Block Screw Lock Washer                                                                              | .05        |
| 302A     | Breaker Point Nut                                                                                          | .05        |
| 302B     | Breaker Point Nut                                                                                          | .05        |
| 403      | Spark Lever                                                                                                | .25        |
| 407      | Latch Group                                                                                                | 1.00       |
| 412      | Rocker Arm Group                                                                                           | 1.25       |
| 413      | Trip Finger Group                                                                                          | 1.25       |
| 419      | Latch-off Screw                                                                                            | .10        |
| 420      | Latch-off Screw Nut                                                                                        | .05        |
| 422      | Trip Finger Support Spring                                                                                 | .15        |
| 423      | Latch-off Screw Lock Washer                                                                                | .05        |
| 429      | Trip Finger Frame Group                                                                                    | .75        |
| 430      | Latch Group Clip                                                                                           | .07        |
| W502     | Breaker Point Set                                                                                          | 2.00       |
| 505      | Breaker Point Lubricating Pelts                                                                            | .10        |
| 511      | Set of Coil Connecting Wires                                                                               | .20        |
| 513      | Armature Group                                                                                             | 1.75       |
| 0201     | Lead Wire with Terminal and Intensifier                                                                    | .80        |
| K196     | Magneto Bracket                                                                                            | 1.90       |
| 0197     | Rocker Arm Stud (All Horse Power)                                                                          | .40        |
| K198A    | Trip Bracket Assembly Complete (less No. 413 Assembly)                                                     | 1.75       |
| K198B    | Trip Bracket Casting                                                                                       | .25        |
| K198C    | Trip Bracket Assembly Complete                                                                             | 3.00       |
| K199     | Trip Finger Pin (1 <sup>3</sup> / <sub>4</sub> and 2 H. P. old style)                                      | .15        |
| K199A    | Trip Finger Pin (1 <sup>3</sup> / <sub>4</sub> and 2 <sup>3</sup> / <sub>4</sub> H. P. Adjustable Type)    | .15        |
| K209     | Trip Bracket Clamp (1 <sup>3</sup> / <sub>4</sub> and 2 <sup>3</sup> / <sub>4</sub> H. P. Adjustable Type) | .30        |
| Y15      | Cap Screw with Washer for Adjustable Trip Bracket Assembly                                                 | .10        |
| Y460     | Set Screw with Lock Nut                                                                                    | .10        |
| Y466     | Set Screw with Lock Nut (1 <sup>3</sup> / <sub>4</sub> to 2 <sup>3</sup> / <sub>4</sub> H. P.)             | .10        |
| .....    | EK Wico Magneto Complete with Bracket, Spark Plug and Trip Assembly                                        | 18.00      |
| .....    | EK Wico Magneto only                                                                                       | 14.00      |

All parts on list above can be shipped by parcel post.

## Parts and Numbers for the Wico Type P. R. Magneto as used on 6 to 14 H. P. Engines

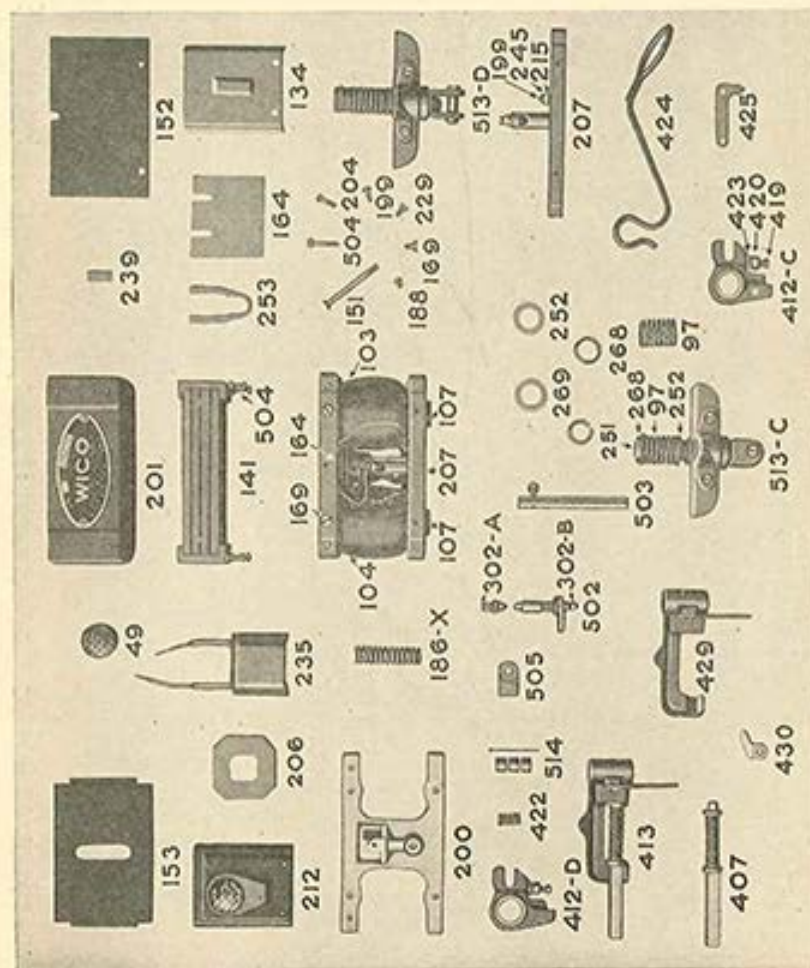

To avoid delays and mistakes always show number, name of part and type of magneto. For prices see page 42.

## Parts Price List of Wico Type P. R. Magneto as used on 6 to 14 H. P. Engines

| Number | Item                                                           | List  |
|--------|----------------------------------------------------------------|-------|
| W49    | Lead Wire Connection Plug                                      | .15   |
| 97     | Armature Return Spring                                         | .40   |
| 103    | Coil—Right Hand                                                | 3.75  |
| 104    | Coil—Left Hand                                                 | 3.75  |
| 107    | Core Group                                                     | 1.25  |
| 134    | Ground Cover                                                   | .35   |
| 141    | Magnet Group                                                   | 7.00  |
| 151    | Deck Screw                                                     | .10   |
| 152    | Front Cover                                                    | .60   |
| 153    | Back Cover                                                     | .60   |
| 164    | Condenser Support                                              | .05   |
| 169    | Pole Yoke Screw, Short                                         | .05   |
| W172   | Pole Yoke Screw, Long                                          | .10   |
| 186    | Latch Spring                                                   | .25   |
| 188    | Hood Screw                                                     | .05   |
| 199    | Ground Connection Screw, Ground Cover Screw                    | .05   |
| 200    | Assembly Plate                                                 | 1.75  |
| 201    | Hood                                                           | 1.00  |
| 204    | Terminal Cover Screw                                           | .05   |
| 206    | Coil Gasket                                                    | .05   |
| 207    | Front Deck Group                                               | 1.00  |
| 212    | Terminal Cover                                                 | 1.25  |
| 215    | Ground Connection Screw Lock Washer                            | .05   |
| 229    | Front Cover Screw                                              | .05   |
| 235    | Condenser                                                      | 3.00  |
| 239    | Coil Wedge                                                     | .05   |
| 241    | Coil Group                                                     | 3.00  |
| 245    | Ground Lead Clamp                                              | .05   |
| 251    | Return Spring Retaining Ring                                   | .05   |
| 252    | Return Spring Washer                                           | .05   |
| 253    | Return Spring Support                                          | .05   |
| 268    | Retaining Ring Cup Washer                                      | .05   |
| 269    | Return Spring Adjusting Washer                                 | .05   |
| 302A   | Breaker Point Nut                                              | .05   |
| 302B   | Breaker Point Nut                                              | .05   |
| 403    | Spark Lever                                                    | .25   |
| 407    | Latch Group                                                    | 1.00  |
| 412C   | Rocker-arm Group (with hand starting pin)                      | 1.50  |
| 412D   | Rocker-arm Group                                               | 1.25  |
| 413    | Trip Finger Group                                              | 1.25  |
| 419    | Latch-off Screw                                                | .10   |
| 420    | Latch-off Screw Nut                                            | .05   |
| 422    | Trip Finger Support Spring                                     | .15   |
| 423    | Latch-off Screw Lock Washer                                    | .05   |
| 424    | Starting Handle                                                | .50   |
| 425    | Starting Handle Catch                                          | .10   |
| 429    | Trip Finger Frame Group                                        | .75   |
| 430    | Latch Group Clip                                               | .07   |
| W502   | Breaker Point Set                                              | 2.00  |
| 503    | Guide Rod Group                                                | .60   |
| 504    | Magnet Screw Group                                             | .05   |
| 505    | Breaker Point Lubricating Felts                                | .10   |
| 511    | Set of Coil Connecting Wires                                   | .25   |
| 513C   | Armature Group Side Fork                                       | 2.00  |
| 514    | Guide Rod Lubricating Pad                                      | .10   |
| 586    | Priming Cup                                                    | .25   |
| 0201   | Lead Wire with Terminal                                        | .80   |
| 0196   | Magneto Bracket (3½ to 14 H. P.)                               | 2.20  |
| 0197   | Rocker Arm Stud (All H. P.)                                    | .40   |
| 0199   | Trip Finger Pin 3 to 12 H. P. (Old style)                      | .15   |
| 0199A  | Trip Finger Pin 3½ to 14 H. P. (Adjustable Type)               | .15   |
| 0198B  | Trip Bracket Casting (Adjustable Type)                         | .25   |
| 0209   | Trip Bracket Clamp (Adjustable Type)                           | .30   |
| Y167   | Set Screw with Lock Nut                                        | .10   |
| Y460   | Set Screw with Lock Nut                                        | .10   |
| Y586   | Cap Screw with Washer                                          | .10   |
| 0198C  | Trip Bracket Assembly, Complete                                | 3.10  |
| 0198A  | Trip Bracket Assembly, (less No. 413 Assembly)                 | 1.75  |
| —      | PR Magneto Complete with Bracket, Trip Assembly and Spark Plug | 22.00 |
| —      | PR Wico Magneto only                                           | 18.00 |

All parts on list above can be shipped by parcel post. For prices on Magneto Brackets and Valve Rod Clamp parts see page 40.

## Wico Magneto

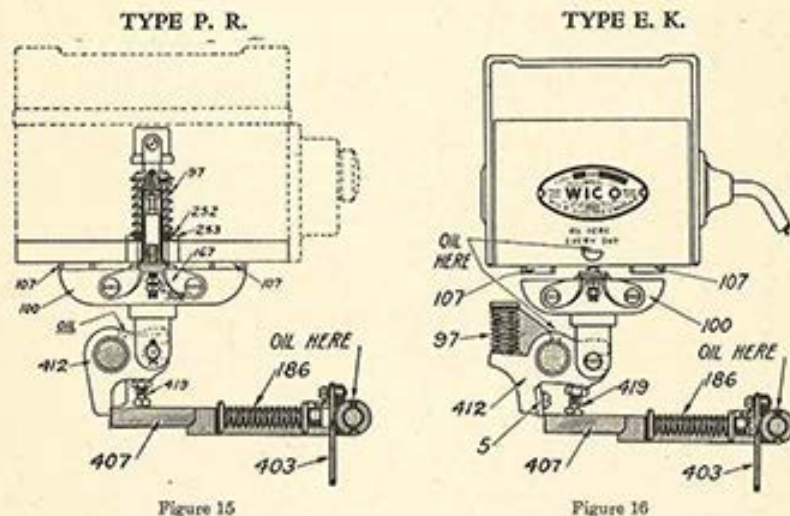

Figure 15

Figure 16

The numbers on Figures 15 and 16 will be used in the instructions on adjusting Wico Magnetos. Figure 15 is a cut of the type P. R. showing the position of the trip finger No. 407 and armature No. 100, just before the contact between armature No. 100 and the face of the cores No. 107 has been broken. Figure 16 is cut of type E. K. showing position of the trip finger No. 407 and armature No. 100 after the contact between armature No. 100 and the face of the cores No. 107 has been broken, also at the point where trip finger No. 407 trips off of rocker arm No. 412 causing armature No. 100 to return to its original position.

Note—Type P. R. and type E. K. Magnetos are alike except in size and the location of spring No. 97. Therefore the instructions on Wico Magnetos will apply to both types.

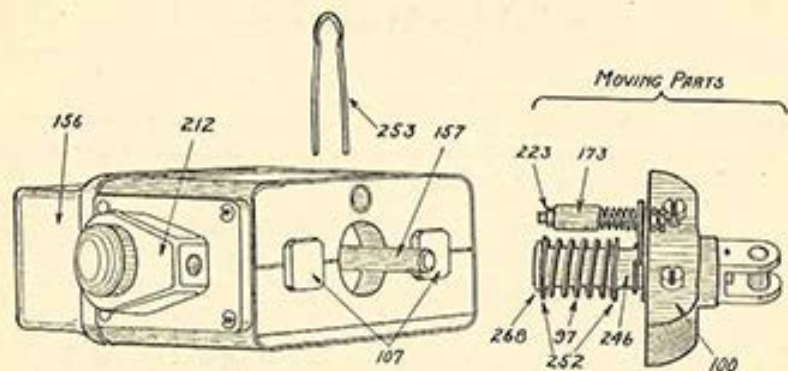

Figure 17

## Breaker Point Group

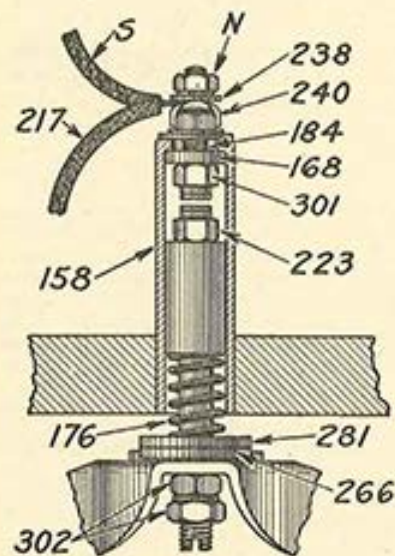

Figure 18

Figure 17 shows the stationary and moving parts of the Wico Magneto. Figure 18 shows the parts with numbers of the breaker point group.

To remove the moving parts remove side plate, next pull the "U" shaped wire No. 253 straight out from its position—the moving parts will now slip out of their position easily.

## ADJUSTMENTS

### Latch-off of Trip Finger

(See Figure 16)

The rocker arm (412) is provided with a screw (419) and locknut for adjusting the "latch-off" of the trip finger. This screw must be set so that the latch (407) will slip off the lip of the rocker arm just after the breaker points have been opened by the downward movement of the armature.

If the screw is screwed OUT too far the breaker points will not open and the magneto will not spark.

If the screw is screwed IN too far the trip finger will drive the armature down too far and possibly break the return spring or the parts that hold it.

This adjustment will be made originally by the engine builder and should not require attention thereafter. It has nothing whatever to do with the time of the spark.

If necessary, the adjustment can be made as follows:

Trip the armature (100) from its contact with the cores (107) and insert a strip of metal 7-64" thick between the armature and the face of the cores. Move the push rod slowly until the latch of the trip finger reaches the rocker arm. The edge of the latch should then just engage the edge of the lip of the rocker arm, and the adjusting screw (419) should be bearing on the top side of the latch, (see Figure 16) so that the least further movement of the push rod will cause the latch to slip off the edge of the rocker arm.

If the latch does not engage the lip of the rocker arm when armature is set as above the adjusting screw should be screwed in until the latch just engages. If the latch engages the lip of the rocker arm too much (more than 1-32") unscrew the adjusting screw to give the proper engagement.

Loosen the locknut on the adjusting screw (419) before attempting to change adjustment and be sure to set it up tight after the adjustment has been made. Remove the metal strip before attempting to start the engine.

### Adjustment of Breaker Points

(See Figure 18)

The breaker point contacts are perfectly adjusted at the factory, and no re adjustment will be required except when installing new contacts, at which time proceed as follows:—



The breaker point contacts (301) and (223) should just touch when the armature (100) is 7-64" from the cores (107). To adjust, trip the armature from its contact with the cores, and insert a strip of metal 7-64" thick between the armature (100) and the face of the cores. Loosen the nuts (302) on the breaker point stem, (see Figure 18), and turn the upper nut until the contact (223) just touches the contact (301). Then set up the lower nut tight against the upper nut. As soon as adjustment has been made, be sure to remove the strip that you placed between armature and cores.

## REPLACEMENTS

### Breaker Points

(See Figure 18)

The best results will be obtained if both contacts are renewed whenever one of them fails. If either contact fails it may leave the other in such uneven shape as to spoil a new contact.

To replace the moving contact (223):—Withdraw the moving parts (see Figure 17) and remove the old contact and its spring (176) from the breaker point plate by unscrewing the two nuts (302). Substitute the new moving contact, being careful to replace the felt washers (266 and 281) as shown in Figure 18.

Replace the nuts and the lock washers between them. After replacing the moving parts, adjust the breaker point contacts as explained under "Adjustments."

To replace fixed contact (301):—Remove the front cover and the spring support (253) and withdraw the moving parts (see Figure 17). Disconnect condenser lead (S) and primary lead (217) from breaking point tube (158). Remove all nuts and washers from shank of the contact (301) and push contact down and out of tube. There are two insulating washers (168 and 184) inside of tube and these should be removed also.

New insulating washers (168 and 184) and new nuts will be supplied with each new fixed contact and these should always be used in replacements.

Place insulating washers on new contact and insert in tube, replace outside insulating washer, cover it with the large brass washer and lock washer and screw the nut up tight. Replace the two washers (240 and 238) and the nut (N). Insert the two leads and set the nut up tight. After replacing the moving parts, see that the contacts are in proper adjustment (see "Adjustments," page 45).

## Latch and Latch Block Edges

(See Figures 15 and 16)

If the edge of the latch (407) becomes worn where it engages latch block (5), a fresh edge can be obtained by clamping the latch in a vise and pulling it out of the trip finger and giving it a quarter turn before replacing it. A fresh edge on the latch block (5) may be obtained by loosening the latch block screw and giving the latch block a quarter turn before replacing it. The screw is headed over at its outer end and the heading should be filed off before attempting to loosen the screw. Be sure to replace the lock washer and set screw up tight. The latch-off screw (419) should be removed to get at the latch block screw. After the latch block is replaced, the latch-off adjustment should be made as described under "Adjustments", see page 45.

## TROUBLE HUNTING

If ignition trouble is suspected, disconnect spark wire from plug and observe spark between wire and engine frame, by holding end of wire about  $\frac{1}{8}$ " from frame while cranking engine.

If no spark is produced when magneto is operated, the trouble can be located by proceeding as follows:—

See that the armature (100) returns and makes a firm contact with the cores (107) after being tripped off.

Failure to make a firm contact indicates a weak-end or broken return spring (97) or friction of moving parts caused by lack of oil.

Remove any dirt from between armature and face of cores.

Turn the flywheel over slowly and see that when the armature (100) is tripped it snaps quickly away from the cores (107). Failure to do this indicates binding or friction or a broken drive spring (186). (See Figures 15 and 16.)

Remove the front cover and use a small wire or piece of wood to remove any dirt from the surfaces of the contacts (301 and 223) and from the insulating washer (168). (See Figure 18). See that electrical connections are tight.

—

### SPECIAL NOTICE

Before making any adjustments on the Wico Magneto be sure it is at fault. Start at the spark plug to look for trouble. If you do not get any spark or the spark is weak see that the plug is cleaned of all carbon, also examine the porcelain of the spark plug to be sure it is not cracked. If the spark plug is in good condition and you fail to get a spark, then examine the lead wire, look for breaks and loose connections. Do not try to make adjustments on working parts of magneto until you are sure that the spark plug is clean—and then proceed with adjustment as shown on pages 45, 46 and 47. To clean a spark plug always take it apart, then adjust fuel and lubricating oil to stop fouling of plug. (See pages 5, 6, and 10.)

—48—

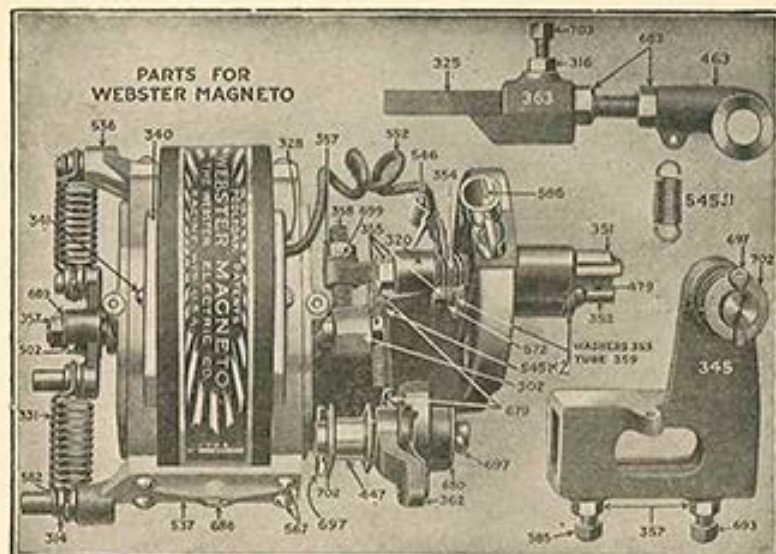

### Parts for Webster Magneto (Old Style)

M 1, K 26 and L 26

| Part No. | Description                       | Price  | Part No. | Description                          | Price  |
|----------|-----------------------------------|--------|----------|--------------------------------------|--------|
| 302      | Push Finger                       | \$0.85 | 479      | Spark Points (each)                  | \$1.15 |
| 303      | Bracket, complete (1 1/2 H. P.)   | 6.25   | 502      | Spring Arm                           | .65    |
| 303      | Bracket, complete (3 to 12 H. P.) | 7.50   | 536      | Magnet Clamp (short pin)             | .45    |
| 314      | Spring Roller                     | .30    | 537      | Magnet Clamp (long pin)              | .50    |
| 316      | Nut for Set Screw                 | .05    | 542      | Key (shafts or electrode, not shown) | .05    |
| 320      | Electrode Arm                     | .60    | 545J1    | Journal Spring                       | .15    |
| 325      | Push Rod                          | .40    | 545K2    | Electrode Arm Spring                 | .15    |
| 328      | Fiber Bushing                     | .05    | 546      | Plug Terminal Bronze                 | .20    |
| 331      | Inductor Spring                   | .15    | 552      | Terminal Wire                        | .15    |
| 339      | Shaft Washer (not shown)          | .05    | 567      | Clamp Screw                          | .05    |
| 340      | Top Cover                         | .45    | 569      | Journal Screw (per set of 8)         | .40    |
| 341      | Cover Screw                       | .05    | 572      | Electrode Washer                     | .05    |
| 345      | Valve Rod Clamp                   | 1.10   | 577      | Starting Lever (not shown)           | .25    |
| 351      | Movable Electrode and Point       | 1.10   | 582      | Split Ring                           | .05    |
| 352      | Stationary Electrode and Point    | .75    | 585      | Set Screw (sharp point)              | .05    |
| 353      | Insulating Washer                 | .05    | 586      | Priming Cup                          | .45    |
| 354      | Electrode Spring                  | .15    | 679      | Spring Cotter Pin                    | .05    |
| 355      | Nut                               | .05    | 680      | Eccentric Washer                     | .05    |
| 357      | Nut                               | .05    | 682      | Push Rod Nut                         | .05    |
| 358      | Adjusting Screw                   | .15    | 686      | Magnet Bar Set Screw                 | .05    |
| 359      | Mica Tube                         | .25    | 689      | Washer for Spring Arm Nut            | .05    |
| 362      | Control Lever                     | .95    | 693      | Set Screw (cup point)                | .05    |
| 363      | Wedge                             | .35    | 697      | Eccentric Cotter Pin                 | .05    |
| 371      | End Plate                         | 1.10   | 699      | Adj. Screw Lock Washer               | .05    |
| 447      | Push Rod Roller                   | .25    | 702      | Roller Washer                        | .05    |
| 463      | Push Rod Journal                  | .45    | 703      | Wedge Set Screw                      | .05    |

NOTE—All items above can be shipped by parcel post.

NOTE—See magneto parts list for new style type 1-A and 2-C magnetos on pages 51, 52, 53 and 54.  
PRICES SUBJECT TO CHANGE WITHOUT NOTICE

—49—

## The Webster Magneto

### HOW TO SET THE SPARK WHEN MAGNETO IS USED FOR IGNITION

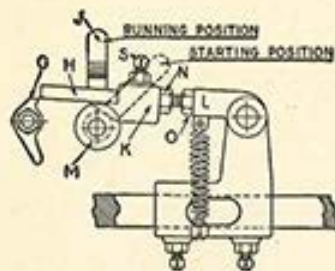

Figure 13

First and **IMPORTANT**. The adjusting screw "E" as shown in Figure 14 should always be set so it will just touch the push finger "G" when the spring arm "C" is in a horizontal position. If screw "E" does not touch push finger "G" or if it is set in too far you will get only a weak spark.

Second. Be sure timing lever "J" shown in Figure 13 is in running position, then turn the flywheels to the right until the piston starts back into the cylinder on the compression stroke, then continue to turn them slowly until the word **Spark** on the rim of the flywheel is opposite the top of the cam rod (Figure 15). This is the point at which the spark should be made.

Third. Place the tripping lever in position on the magneto and cock the spring.

Fourth. See that the screws (Figure 13) which fasten the clamp to the push rod are tight and that the one nearest the cylinder head is in the hole in the bottom of the cam rod, then adjust the length of push rod "H" (Figure 13) until the end of the rod touches the push finger "G". Tighten locknut "O".

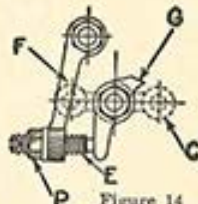

Figure 14

Fifth. Loosen set screw "S", move wedge "K" on the push rod toward the magneto until the lower edge of the end of the rod "H" is just even with the upper edge of the magneto push finger "G" as shown, tighten set screw "S", then the locknut "N".



Figure 15

Sixth. Take off the tripping lever, be sure the magneto wire is fastened to the terminal. Turn the flywheels to the right to see if the magneto trips off when the word **Spark** is opposite the top of the cam rod. If not, adjust the wedge "K" (Figure 13) carefully until it does. To make engine fire earlier, move wedge "K" toward magneto. To fire later, move wedge "K" away from magneto.

## Webster Magneto (New Style)

### HOW TO ORDER SPARE PARTS

1. Give type of magneto and igniter plug.
2. Give part No. and part name.
3. Give H. P. name and type of engine.

**NOTE:** New Style Webster Magneto cannot be used if engine is equipped for old style.

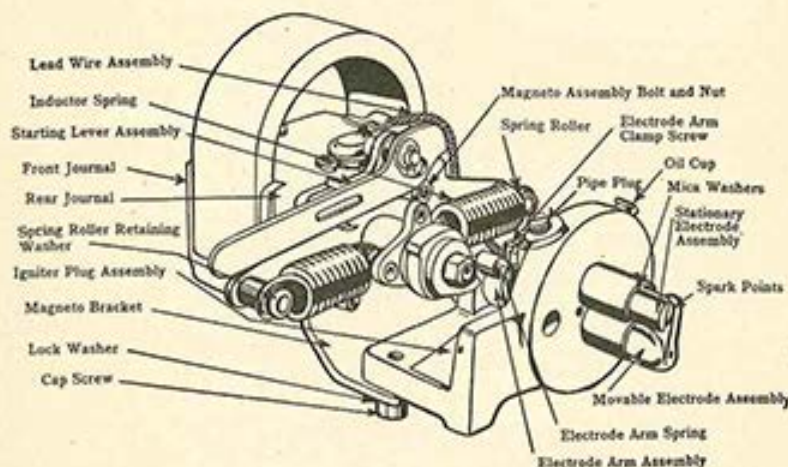

**IF REPAIR WORK IS REQUIRED SEND IN BOTH MAGNETO AND IGNITER PLUG**

**NOTE:** See Magneto Parts List for old style M1, K26 and L26 Magnetos on page 49.

# Instructions for Using Webster Magneto

## Type No. 1 and Type No. 2

When starting the engine retard the time of ignition by moving the lever (C) (Fig. 1) away from the magneto and toward the engine crank shaft. Then follow the regular engine instructions for starting and as soon as the engine has gained a little speed advance the time of ignition by moving the lever (C) toward the magneto.

There are no special instructions to be followed in operating an engine equipped with this magneto except that all moving parts of magneto must be thoroughly oiled daily and magneto must not be taken apart.

### Adjustment of Webster Magneto:

There is only one point of adjustment on the Webster Magneto type No. 1 or type No. 2, and this is the length of the push rod (B) as governed by the adjustment of the locknuts (I and E) (Fig. 2). The purpose of this adjustment is to trip the magneto at the right time in the stroke of the engine. To make this adjustment loosen the nuts (I and E) turning them until the push rod (B) is moved well away from the magneto; then turn the engine to the firing point. This should be about seven to eight degrees before dead center for each 100 R. P. M. of the engine. Thus, if the engine runs 400 R. P. M. the magneto should trip about thirty degrees before dead center. Now, turn the adjusting nut (I) so as to move the push rod toward the magneto until the magneto trips, then lock the rod in position by tightening up locknut (E). This nut should be turned very tight in order to make the adjustment secure and permanent. When the engine is now turned very slowly the magneto should trip at the proper place, but if there is any slight variation it can be corrected by adjusting the push rod either toward or from the magneto to secure the proper timing.

Note:—The push rod clamp (D) can be moved in or out on the stud (F) in order to line the push rod (B) up with the push finger (J).

When magneto is properly adjusted on the engine there should be a slight clearance (A) (Fig. 1) between the end of the push rod (B) and tip of the push finger (I) when the push rod is farthest toward the engine crank shaft.

Sluggish action of the movable electrode is probably due to a deposit of carbon which should be washed out with a little kerosene applied to the oil hole.

The igniter points can be cleaned from the outside by pushing the movable electrode in and out, thus rubbing the igniter points together.

**CAUTION:**—Keep all bolts and nuts tight and take good care of the magneto if you wish to secure long and efficient service from it.

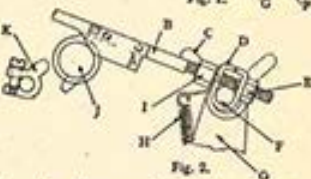
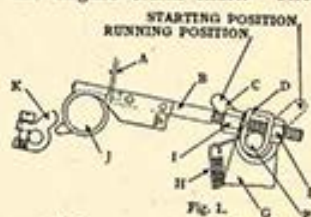

# Webster Magnetos Types 1-A and 2-C

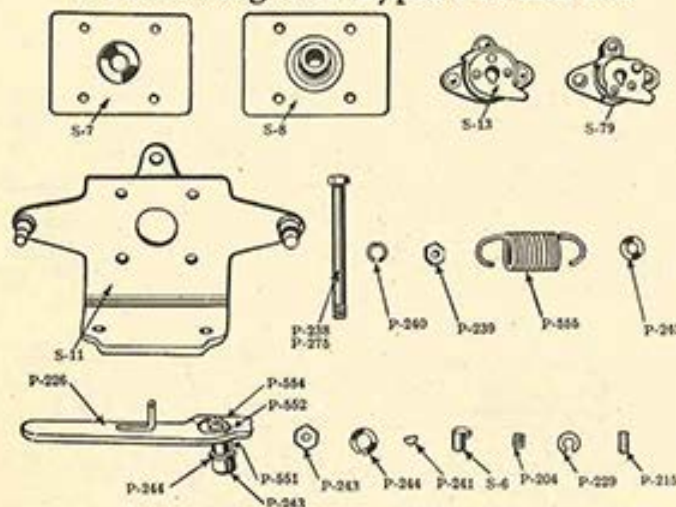

### Spare Part List for Magnetos, Types No. 1-A and No. 2-C

| Part No. | Part Name                                             | Price   |
|----------|-------------------------------------------------------|---------|
| S-6      | Oil Cup                                               | \$ 1.15 |
| S-7      | Journal Assembly (front)                              | 1.30    |
| S-8      | Journal Assembly (rear)                               | 1.65    |
| S-11     | Magneto Bracket Assembly                              | 1.30    |
| S-13     | Push Finger Assembly for No. 1-A Magneto 1½ H. P.     | 2.10    |
| S-79     | Push Finger Assembly for No. 2-C Magneto 3 to 12 H.P. | 2.10    |
| P-204    | Magneto Bar Set Screw                                 | .05     |
| P-215    | Oil Wick for S-7 or S-8                               | .05     |
| P-226    | Starting Lever                                        | .15     |
| P-239    | Retaining Washer for P-242                            | .05     |
| P-238    | Assembly Bolt for No. 1-A Magneto 1½ H.P.             | .15     |
| P-239    | Lock Nut for P-238 or P-275                           | .05     |
| P-240    | Lock Washer for P-238 or P-275                        | .05     |
| P-241    | Woodruff Key                                          | .05     |
| P-242    | Spring Roller                                         | .05     |
| P-243    | Shaft Lock Nut                                        | .05     |
| P-244    | Shaft Lock Washer                                     | .05     |
| P-275    | Assembly Bolt for No. 2-C Magneto 3 to 12 H.P.        | .15     |
| P-555    | Inductor Spring                                       | .15     |
| P-551    | Starting Lever Stud                                   | .15     |
| P-552    | Retaining Washer for P-551                            | .05     |
| P-554    | Cotter Pin for P-551                                  | .05     |

### SPARE PART LIST FOR EQUIPMENT

| Part No. | Part Name                                        | Price   |
|----------|--------------------------------------------------|---------|
| A-2      | Igniter Plug Assembly 3 to 12 H.P.               | \$ 6.25 |
| A-6      | Igniter Plug Assembly 1½ H.P.                    | 5.90    |
| S-6      | Oil Cup                                          | .15     |
| S-15     | Electrode Arm Assembly                           | .95     |
| S-19     | Stationary Electrode Assembly for A-6 1½ H.P.    | .40     |
| S-21     | Priming Cup                                      | .45     |
| S-27     | Lead Wire Assembly                               | .15     |
| S-43     | Movable Electrode Assembly for A-6 1½ H.P.       | .95     |
| S-69     | Control Lever Assembly                           | .90     |
| S-70     | Movable Electrode Assembly for A-2 3 to 12 H. P. | .95     |

NOTE—All items above can be shipped by parcel post

## Webster Magnetos Types 1-A and 2-C

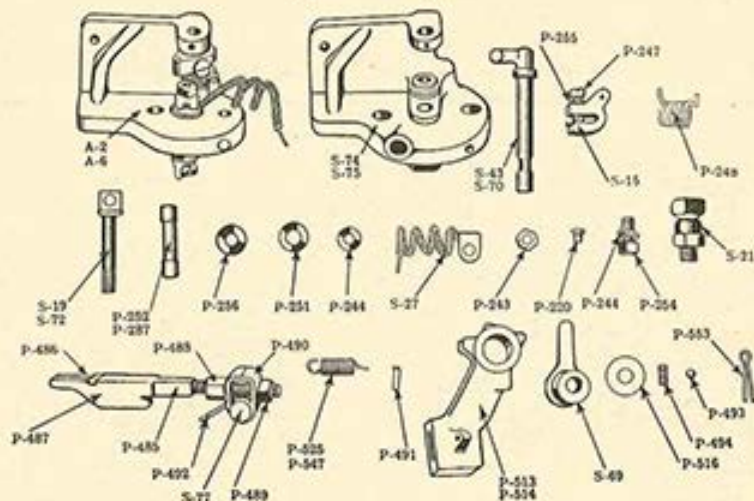

### SPARE PART LIST FOR EQUIPMENT

| Part No. | Part Name                                            | Price   |
|----------|------------------------------------------------------|---------|
| S-71     | Push Rod Assembly (Complete)                         | \$ 1.55 |
| S-72     | Stationary Electrode Assembly for A-2, 3 to 12 H. P. | .45     |
| S-74     | Igniter Plug Sub-Assembly 3 to 12 H. P.              | 3.35    |
| S-75     | Igniter Plug Sub-Assembly 1 1/2 H. P.                | 2.10    |
| S-77     | Push Rod Journal Stud Assembly                       | .25     |
| P-220    | Spark Point                                          | .15     |
| P-243    | Nut for S-19 or S-72                                 | .05     |
| P-244    | Lock Washer for S-19 or S-72                         | .05     |
| P-247    | Electrode Arm Clamp Screw                            | .10     |
| P-248    | Electrode Arm Spring                                 | .10     |
| P-251    | Mica Washer (each)                                   | .05     |
| P-252    | Mica Tube for S-19                                   | .15     |
| P-253    | Washer for S-19 or S-72                              | .05     |
| P-254    | Cap Screw                                            | .05     |
| P-255    | Lock Washer for P-247                                | .05     |
| P-256    | Asbestos Washer                                      | .05     |
| P-280    | Pipe Plug                                            | .15     |
| P-287    | Mica Tube for S-72                                   | .15     |
| P-485    | Push Rod                                             | .85     |
| P-488    | Push Rod Nut—Special                                 | .05     |
| P-489    | Push Rod Nut—Standard                                | .05     |
| P-490    | Push Rod Journal Stud Clamp                          | .30     |
| P-492    | Push Rod Spring Holder                               | .05     |
| P-493    | Ball                                                 | .05     |
| P-494    | Spring                                               | .05     |
| P-513    | Valve Rod Clamp with A-6 1 1/2 H. P.                 | 1.10    |
| P-514    | Valve Rod Clamp with A-3, 3 to 12 H. P.              | 1.50    |
| P-516    | Retaining Washer for S-77                            | .05     |
| P-525    | Push Rod Journal Spring for P-513                    | .10     |
| P-547    | Push Rod Journal Spring for P-514                    | .10     |
| P-553    | Cotter Pin for S-77                                  | .05     |

Note—All items above can be shipped by parcel post.

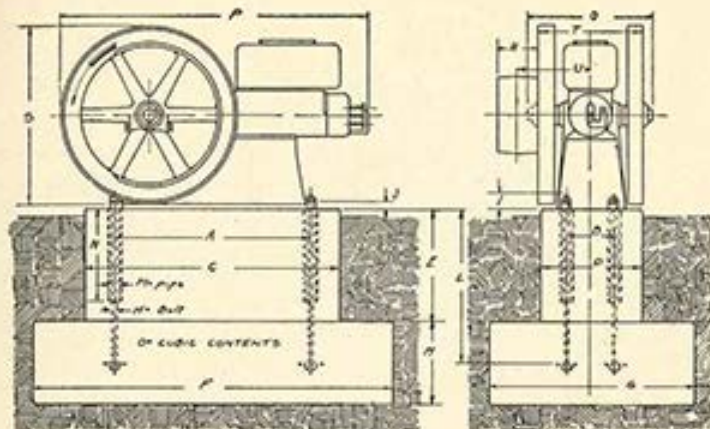

MEASUREMENTS  
Model E, F and G

| Eng.       | A       | B      | C   | D   | E   | F   | G   | H   | I      | J      | K      | L   | M      | N   | O       | P       | Q       | R  | S   | T       | U       |
|------------|---------|--------|-----|-----|-----|-----|-----|-----|--------|--------|--------|-----|--------|-----|---------|---------|---------|----|-----|---------|---------|
| 1 1/2 H.P. | 20"     | 5 1/2" | 29" | 14" | 12" | 41" | 26" | 12" | 1 1/2" | 1 1/2" | 3 1/2" | 18" | 1"     | 10" | 10 1/2" | 30 1/2" | 19 1/2" | 4" | 18" | 13 1/2" | 9 1/2"  |
| 3 1/2 H.P. | 25 1/2" | 6 1/2" | 36" | 18" | 18" | 48" | 30" | 12" | 2 1/2" | 1 1/2" | 3 1/2" | 24" | 1"     | 15" | 16 1/2" | 39 1/2" | 21 1/2" | 4" | 22" | 16 1/2" | 11 1/2" |
| 6 H.P.     | 29 1/2" | 8"     | 42" | 20" | 18" | 56" | 34" | 12" | 2 1/2" | 1 1/2" | 3 1/2" | 24" | 1 1/2" | 16" | 22"     | 46 1/2" | 24"     | 4" | 28" | 19 1/2" | 12 1/2" |
| 8 H.P.     | 36 1/2" | 9"     | 48" | 20" | 18" | 66" | 38" | 18" | 2 1/2" | 1 1/2" | 3 1/2" | 27" | 1 1/2" | 15" | 26"     | 56 1/2" | 26"     | 6" | 34" | 20 1/2" | 13 1/2" |
| 10 H.P.    | 41 1/2" | 10"    | 54" | 22" | 24" | 77" | 44" | 18" | 2 1/2" | 1 1/2" | 3 1/2" | 33" | 1 1/2" | 20" | 32"     | 64 1/2" | 28"     | 8" | 38" | 23 1/2" | 15 1/2" |
| 14 H.P.    | 47 1/2" | 12"    | 62" | 25" | 24" | 86" | 50" | 18" | 2 1/2" | 1 1/2" | 3 1/2" | 33" | 1 1/2" | 20" | 36 1/2" | 73 1/2" | 31"     | 8" | 44" | 26"     | 17"     |

### Mount the Engine on a Solid Foundation

These engines are very evenly balanced, and run with very little vibration, but wherever possible it is a good plan to mount your engines on a concrete foundation, or if you cannot do this, use heavy timbers securely fastened down.

When an engine is to be located permanently it is best to mount it on a concrete foundation as shown above. In the table each letter shows the distance between the points as indicated in the drawing above.

To make a foundation like this dig a hole as long and wide as indicated by "F" and "G" and as deep as the sum of "E" and "H". If ground is not solid line hole with lumber or sheet metal to prevent caving. Make a box without top or bottom of size as indicated by C, D and E. Across the top of this box securely attach a couple of strips 2 or 3 inches wide, thickness as indicated by "J" and spaced as indicated by "A", measuring from center to center. These strips should be long enough to reach clear across the hole for foundation and box hung in the center of it. The top edges of box must be perfectly level. In the cross strip bore holes of size as indicated by "K" spaced as indicated by "A" and "B". Foundation bolts of length indicated by "L" fitted with large washers on the bottom should be hung from the cross strips. A piece of pipe or tubing larger than the bolt should be placed on the bolts as indicated by the dotted lines in the diagram. The pipe or tubing should come about 1/4 inch below the top of the cross pieces and is put in so bolts can be shifted on account of a variation in the bolt holes in the engine base.

If engine is to be raised from ground the measurement "E" and length of bolts "L" should be increased to correspond with the height of foundation above ground, but measurements below ground must not be changed.

The concrete should be made up of one part good Portland cement, two parts clean sharp sand and four parts clean gravel or crushed stone. Mix thoroughly while dry and then add water—again mixing well till you have a good mixture. Place this in the foundation hole and fill up to within 1/2 inch of the top of the box. Then fill the remaining space with a mixture of one part cement and two parts sand mixed thoroughly and moistened sufficiently so it can be spread and troweled smooth. Let the foundation set for two or three days, when the wood forms can be removed and space around foundation filled with earth or cinders. Then mix cement and water about like thick cream and fill the spaces between the pipe and bolts. Mount the engine, put nuts on bolts and screw down tight. It will be best to let the foundation harden for at least a week or ten days before using the engine.

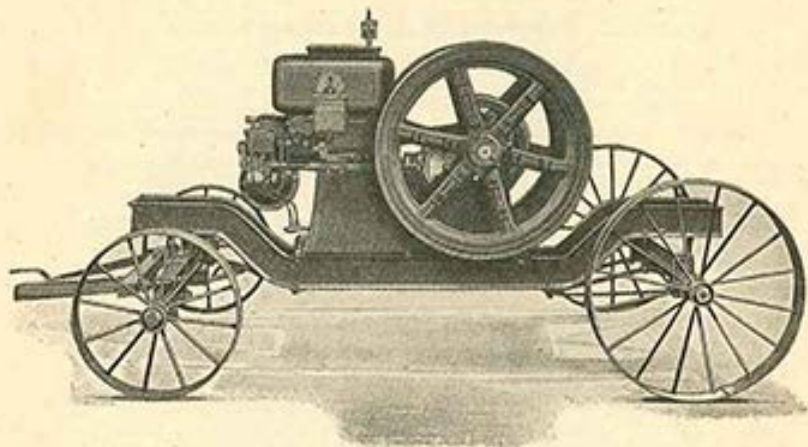

### If You Desire a Mounted Engine

use only good, heavy-channeled and well-braced trucks, especially designed for the type engine we furnish. When engine is in operation put wedged blocks in front and behind each wheel. In taking up bearings on saw tables, follow instructions given on page 18.

#### CAPACITY OF FUEL TANKS

The fuel tank of the stationary engine is located in the base. The 1½ H. P. tank holds 1.1 gallons; 2½ H. P. tank holds 1.4 gallons; 3½ H. P. tank holds 1.6 gallons; 6 H. P. tank holds 3.1 gallons; 8 H. P. tank holds 5.3 gallons; 10 H. P. tank holds 8 gallons; 14 H. P. tank holds 12.6 gallons.

### Rule for Figuring the Size of Pulleys

**Be Sure You Are Using the Right Pulleys on Engine and Machines it is Driving.**

The machines you run with an engine, to give you satisfactory service, must be equipped with the proper size of pulley to correspond with the pulley on the engine.

To be sure that the pulleys you are using are of the right size to give the best results, take the speed of the engine multiplied by the size of the pulley on the engine and divide the result by the speed of the machine that you want to run. The result will give you the size of the pulley you should have on the machine.

**For example**—We will say the speed of the engine is 425 revolutions per minute, the diameter of the pulley on the engine is 12 inches and you want to run a feed grinder 510 revolutions per minute.

$$425 \times 12 = 5100 \div 510 = 10 \text{ inches.}$$

The result, 10 inches, is the size of the pulley you should have on the grinder to run it 510 revolutions per minute.

If there is a pulley on the machine you want to run, to find out what size of pulley to use on the engine, take the speed of the machine multiplied by the diameter of the pulley on the machine and divide by the speed of the engine you are going to use, which will give the size of pulley you should have on the engine to give the best results.

**For example**—Suppose you had a feed grinder that you wanted to run at 510 revolutions per minute. The diameter of the pulley is 10 inches and your engine runs 425 revolutions per minute.

$$510 \times 10 = 5100 \div 425 = 12 \text{ inches.}$$

The result, 12 inches, is the size of the pulley you should have on the engine to run the grinder at 510 revolutions per minute.

Of course, you understand the pulley sizes and the speed of the machine will vary a little one way or the other. When figuring the size of pulley to use, if the result shows an odd size take the nearest even size, which will be all right. For example, if the above result should have been 11½ inches, you would use a 12-inch pulley, but if the result had been 10¾ inches, then a 10-inch pulley should be used. In case the result should be just half way between regular sizes, we advise using the next larger even size.

If you are not sure as to just what size pulley to get, write and tell us what you want to do and we will tell you what you need.

### Instructions for Operating Drag Saw Outfit

1. Get engine ready for operation, as directed in the engine instruction book.
2. Attach saw blade.
3. Fill grease cups on saw frame, oil wood pitman arm and saw guide arms.
4. When you are ready to start sawing, change truck wheels from side to end so you can move the outfit along the log. Clean the log of branches and mark your saw cuts with an ax.
5. Drive anchor hook into side of log opposite the engine and tighten up ratchet on top of beams to hold the outfit firmly to the log.
6. Be sure the clutch is released by pulling out the clutch lever and that the saw is resting on the log; start the engine and when the engine is running at regular speed, push in the clutch lever slowly.
7. If sawing large logs, drive in wedges in the saw cut to prevent the saw from binding.
8. When cut is finished, throw out clutch and hook up saw blade and move to new position and repeat the operation.

#### GENERAL DIRECTIONS

Keep all moving parts of engine and saw well lubricated; keep grease cups full of grease and all bolts and nuts perfectly tight.

#### SAW INSTRUCTIONS

Keep your saw filed to a good cutting edge; the rakers should be slightly shorter than the cutting teeth; keep the proper amount of set in the saw to prevent it from binding. If your saw cuts too slowly, it may need filing and setting or the engine may be running too slowly. The amount of timber you will be able to cut depends to a great extent on the condition of your saw so do not attempt to use the outfit unless you have your saw properly filed and set.

#### ENGINE FOR OTHER WORK

To use the engine for other work, remove the clutch by taking off the two nuts on the end of crank shaft and pulling the clutch straight off and then put on your pulley.

### To Adjust Drive Chain

You will notice that the bearing A186 is not tightened down. Put on your chain slide bearing A186 away from the engine until the chain is tight. Then tighten bolts which hold bearing A186 to the wooden frame.

Next take a straight edge and lay it against the side of the large sprocket A188 so that one end of the straight edge will touch the small sprocket A189. The outside of the large sprocket must be in line with the outside of the small sprocket to make the chain run right. If the large sprocket does not line up with the small sprocket move bearing A186 until it does. Proper lining up of the sprocket and proper tightness of the chain are important factors to the successful operation of your sawing outfit.

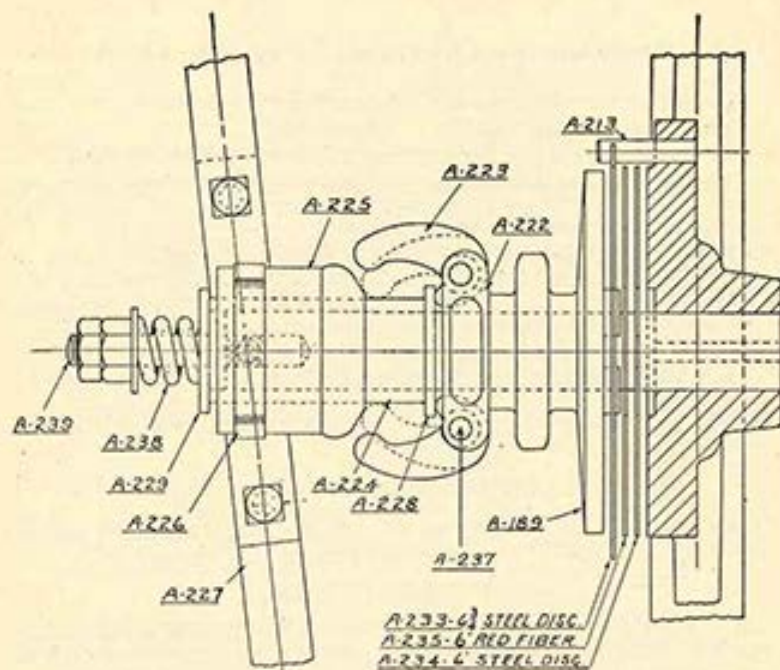

### Instructions for Assembling Clutch on Drag Saw

Drive stud (A239) in end of extended crank shaft by screwing on and locking both nuts and then using a wrench to securely tighten this stud in the shaft. Remove nuts by gripping one and loosening the other.

First place the largest metal disc (A233) on the sprocket plate (A189) and then place the red fibre disc (A235) on next. The small metal disc (A234) is placed on top so the lugs in the arbor hole fit in the slot of the hub on the sprocket plate.

Now slip this entire assembly (sprocket on the outside) on the shaft being careful so the discs remain in place, especially the last one, and the notch in the largest metal disc engages with the pin (A213) on the face of the flywheel.

Next slip the yoke (A222) with fingers (A223) on the shaft as shown in the diagram, then slip on washer (A228) and then sleeve (A224).

Now slip the expander cone (A225) with clutch lever attached, over the sleeve as in the above illustration. Then put on washer (A229), spring (A238) and washer and nuts as illustrated in the above cut.

In tightening nuts to adjust clutch, be careful so that just the loose play in the spring is taken out and the clutch fingers (A223) are just drawn down on the sleeve as illustrated by the dotted lines in the diagram.

If spring is too tight, clutch fingers will bind on the sleeve and prevent the clutch from completely releasing itself.

The clutch lever is to be connected to a support bolted to the underside of the frame.

See page 60 for prices.

### Hercules Drag Saw Parts with Symbol Numbers

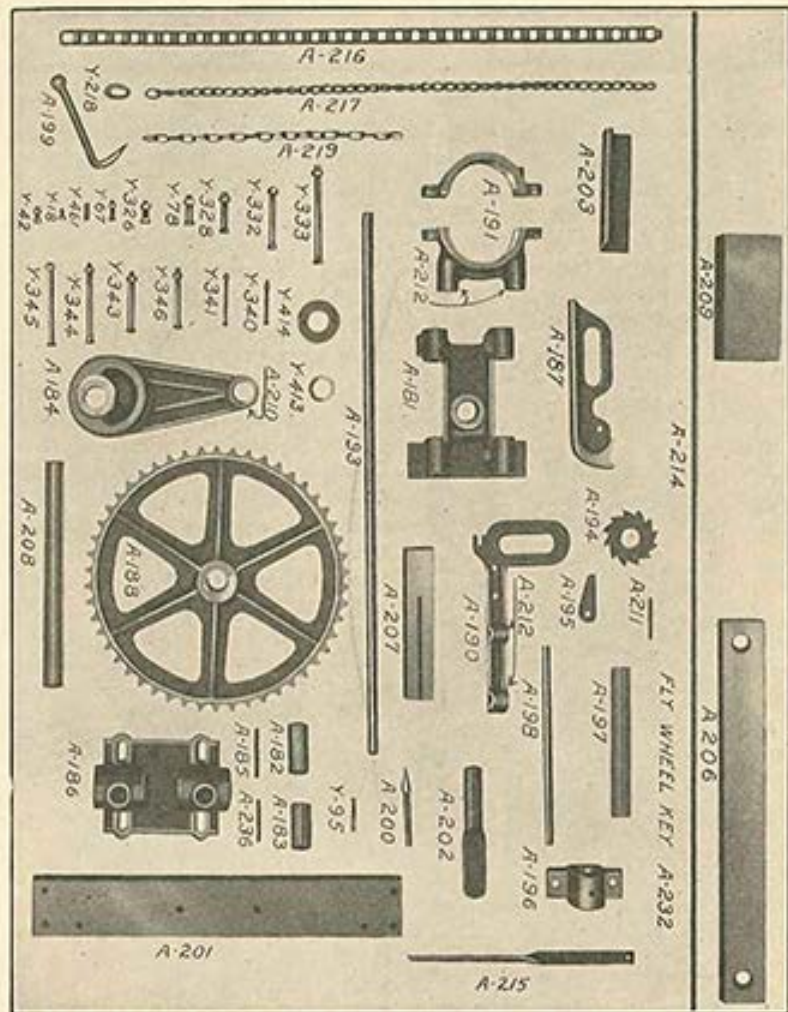

See page 61 for additional drag saw parts. Use both name and number when ordering parts. Prices pages 60 and 61.

## Repair Parts List on Hercules Drag Saw

All items marked X will be shipped by express collect. Other items can be shipped by parcel post.

| No.    | Name                      | Price  | No.       | Name                      | Price |
|--------|---------------------------|--------|-----------|---------------------------|-------|
| A181   | xCross Head.....          | \$5.25 | A215      | Clutch Lever Bracket....  | .15   |
| A182   | Cross Head Pin.....       | .40    | A216      | Driving Chain.....        | 3.25  |
| A183   | Crank Pin.....            | .40    | A216-A    | Driving Chain Links       |       |
| A184   | xBell Crank.....          | 4.75   | Each      |                           | .05   |
| A185   | Taper Key.....            | .05    | A217      | Twisted Link Chain.....   | .45   |
| A186   | xCrank Shaft Bearing..... | 3.20   | A218      | Connecting Link.....      | .10   |
| A187   | Saw Rest.....             | .80    | A219      | Dog Chain.....            | .15   |
| A188   | xLarge Sprocket.....      | 5.20   | A221      | xTruck Wheel.....         | 3.20  |
| A189   | Sprocket Pinion.....      | 1.60   | A222-A223 | Clutch Yoke and Dog       | .35   |
| A190   | Saw Handle.....           | 1.10   | A224      | Sleeve.....               | .80   |
| A191-2 | xEccentric Strap and Cap  | 3.75   | A225      | Expander Cone.....        | 2.10  |
| A193   | Guide Rod.....            | .90    | A226      | Shifter Collar.....       | .25   |
| A194   | Ratchet.....              | .60    | A227      | Clutch Lever.....         | .25   |
| A195   | Ratchet Pawl.....         | .20    | A228      | Special Washer.....       | .10   |
| A196   | Ratchet Shaft Bearing.... | .85    | A229      | Special Washer.....       | .10   |
| A197   | Ratchet Shaft.....        | .95    | A230      | xSpecial Flywheel.....    | 7.60  |
| A198   | Ratchet Handle.....       | .20    | A231      | xCrank Shaft.....         | 6.75  |
| A199   | Anchor Hook.....          | .50    | A232      | Taper Key.....            | .05   |
| A200   | Spike Bolt.....           | .15    | A233      | Clutch Disc 6 3/4".....   | .20   |
| A201   | xAxle.....                | 1.45   | A234      | Clutch Disc 6".....       | .20   |
| A202   | Knuckle.....              | .70    | A235      | Clutch Disc (fibre).....  | .25   |
| A203   | Truss Rod Plate.....      | .55    | A236      | Straight Key.....         | .05   |
| A205   | Oak Frame Skids (2)....   | 2.50   | A237      | Yoke Pin.....             | .05   |
| A206   | Pitman.....               | .35    | A238      | Clutch Spring.....        | .35   |
| A207   | Saw Guide.....            | .20    | A239      | Stud.....                 | .20   |
| A208   | Crank and Sprocket Shaft  | 1.50   | A413      | Special Washer.....       | .05   |
| A209   | Bridge.....               | .30    | A414      | Special Washer.....       | .10   |
| A210   | Crank Pin Dowel.....      | .05    | Y42       | Mach. Bolt (1/8 x 1").... | .05   |
| A211   | Ratchet Pin Dowel.....    | .05    | Y67       | Mach. Bolt (3/8 x 1").... | .05   |
| A212   | Guide Rod Pin.....        | .05    | Y78       | Mach. Bolt (1/2 x 1 1/2") | .05   |
| A213   | Disc Pin.....             | .05    | Y326      | Mach. Bolt (1/2 x 1 1/4") | .05   |
| A214   | Truss Rod.....            | .35    | Y328      | Mach. Bolt (1/2 x 2 1/4") | .10   |
|        |                           |        | Y332      | Mach. Bolt (7/16 x 4")    | .10   |

## Repair Parts List on Hercules Drag Saw

All items marked X will be shipped by express collect. Other items can be shipped by parcel post.

| No.  | Name                         | Price | No.   | Name                      | Price |
|------|------------------------------|-------|-------|---------------------------|-------|
| Y333 | Mach. Bolt (7/16 x 6")       | .10   | Y416  | Set Screw (1/2 x 1")..... | .05   |
| Y341 | Carriage Bolt (1/4 x 3 1/2") | .05   | Y18   | Cap Screw (1/8 x 3/4")..  | .05   |
| Y340 | Carriage Bolt (1/4 x 3")     | .05   | K42D  | Fuel Tank.....            | 2.95  |
| Y343 | Carriage Bolt (7/16 x 4")    | .10   | K89D  | Fuel Tank Support.....    | .95   |
| Y344 | Carriage Bolt (1/2 x 5 1/4") | .10   | K023D | Filler Pipe.....          | .38   |
| Y345 | Carriage Bolt (1/2 x 5 3/4") | .10   | K40D  | Strainer Check Valve....  | .20   |
| Y346 | Carriage Bolt (3/8 x 4")     | .05   | K38D  | Fuel Line Assembly.....   | .20   |
| Y95  | Cotter.....                  | .05   | K180D | Tank Plate Support.....   | .50   |
|      |                              |       | O105  | Drain Plug.....           | .05   |

The Hercules Drag Saw can be furnished with a 1 3/4 H. P. kerosene engine if desired. When the kerosene type engine is furnished a special outside fuel tank is necessary for proper carburetion, which fuel tank with assembly parts is illustrated below. A picture of our drag saw equipped with our 1 3/4 H. P. kerosene engine appears on the next page showing the location of this special outside fuel tank.

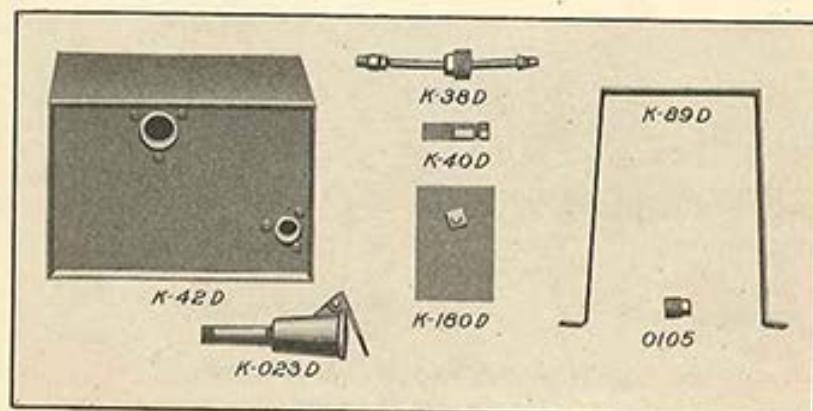



## Hercules Drag Saw

"A Saw with the Power of Hercules Behind It"

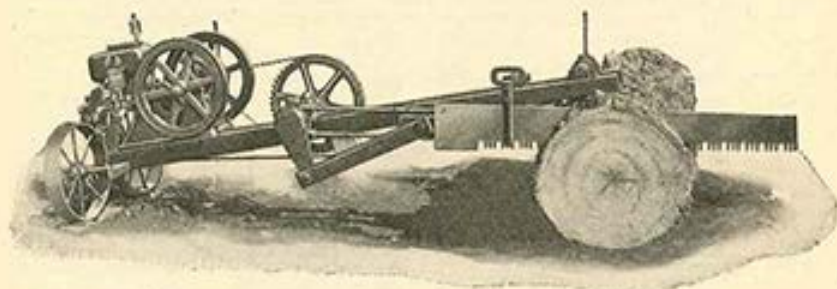

Drag Saw with 1 $\frac{3}{4}$  H. P. Gasoline Engine  
(See pages 58, 59, 60 and 61)

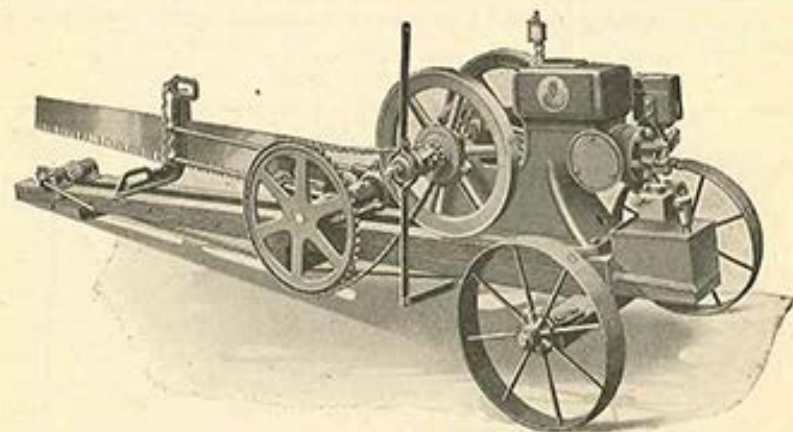

Drag Saw with 1 $\frac{3}{4}$  H. P. Kerosene Engine  
(See pages 58, 59, 60 and 61)

## No. 15 Saw Frame

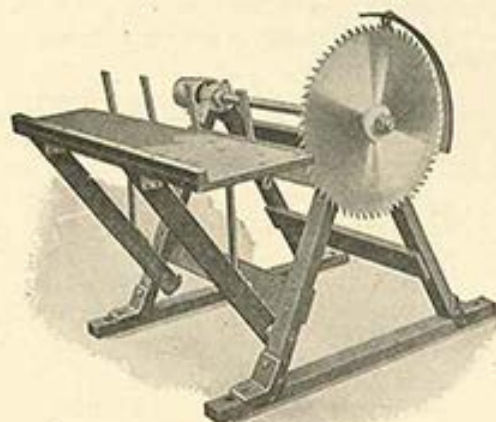

| No.  |                                                      | Price  |
|------|------------------------------------------------------|--------|
| WS1  | xShaft with Saw Mandrel.....                         | \$5.85 |
| WS2  | *Collars to fit on Mandrel, per pair.....            | 1.90   |
| WS3  | *Nut to hold collars on Mandrel.....                 | .35    |
| WS4  | *Bearing Support with Cap.....                       | 1.65   |
| WS5  | *Bearing Complete.....                               | 1.60   |
| WS6  | *Each half Bearing.....                              | .75    |
| WS7  | xCrown Face Pulley with set screw and key 5 x 7..... | 2.75   |
| WS8  | xCrown Face Pulley with set screw and key 8 x 8..... | 4.30   |
| WS9  | xBalance Wheel.....                                  | 8.75   |
| WS4A | *Bearing Cap only.....                               | .25    |
| WS4A | *Bearing Cap only.....                               | .25    |

NOTE—Items marked (\*) can be shipped by parcel post. Items marked (x) will be shipped express or freight.

## INDEX— ENGINES

|                                     |       |
|-------------------------------------|-------|
| Kerosene Engine.....                | 1-7   |
| Gasoline Engine.....                | 8-11  |
| Hercules Drag Saw.....              | 57-60 |
| Hercules Wood Saws.....             | 63    |
| Hercules Drag Saw Instructions..... | 57-60 |

### KEROSENE ENGINE INSTRUCTIONS

|                                  |        |
|----------------------------------|--------|
| How to prepare for starting..... | 1-4-30 |
| How to start.....                | 1-5    |
| How to stop.....                 | 6      |
| How to adjust Carburetor.....    | 6      |

### GASOLINE ENGINE INSTRUCTIONS

|                                            |          |
|--------------------------------------------|----------|
| How to prepare for starting.....           | 9 and 30 |
| How to start engine on compression.....    | 9        |
| How to stop.....                           | 11       |
| How to adjust the Gasoline Fuel Valve..... | 10       |

### MAGNETO INSTRUCTIONS

|                                |       |
|--------------------------------|-------|
| Wico Magneto Instructions..... | 36-48 |
| Type M1—K26 and L26.....       | 49-50 |
| Type 1 and 2 New Style.....    | 51-54 |

### KEROSENE OR GASOLINE ENGINE INSTRUCTIONS

|                                                   |    |
|---------------------------------------------------|----|
| If engine will not start or is hard to start..... | 12 |
| If engine dies down after starting.....           | 14 |
| If engine has no power.....                       | 14 |
| Fuel clean connections.....                       | 13 |

### MISCELLANEOUS INSTRUCTIONS

|                                                                 |       |
|-----------------------------------------------------------------|-------|
| When the spark should take place.....                           | 50    |
| To start engine in cold weather.....                            | 12    |
| If water in hopper should boil.....                             | 12    |
| How to put on Cam Gear.....                                     | 15    |
| The Governor.....                                               | 7-11  |
| Valves—general instructions on valves.....                      | 16-17 |
| How to adjust the Detent Blade—Gasoline Engine.....             | 11    |
| How to adjust the Detent Blade Catch Block—Gasoline Engine..... | 11    |
| How to adjust the Cam Rod Spring.....                           | 16    |
| How to remove or replace Flywheel or Pulley.....                | 16    |
| Cylinder Head Packing.....                                      | 18    |
| Main Bearings—replacing.....                                    | 18    |
| Piston and Rings—How to remove and replace rings.....           | 19    |
| Turn on water.....                                              | 6     |

### CUTS

|                                                     |       |
|-----------------------------------------------------|-------|
| Cuts of Kerosene Head and Carburetor Parts.....     | 31-34 |
| Cuts of Engine Parts.....                           | 32-33 |
| Cuts of Pump Jack Parts.....                        | 35    |
| Cuts of Webster Magneto Parts.....                  | 49-54 |
| Cuts of Friction Clutch Pulley and Repair List..... | 20-24 |
| Cuts of Drag Saw and Cut Off Saws.....              | 62    |

### PRICES AND PARTS

|                                               |             |
|-----------------------------------------------|-------------|
| Engine Repair Parts List.....                 | 24-25-26-27 |
| Pump Jack Repair List.....                    | 30          |
| Webster Magneto Repair Parts List.....        | 49-53-54    |
| Friction Clutch Pulley Repair Parts List..... | 23-24       |
| Drag Saw Repair Parts List.....               | 61          |
| Wood Saw Parts List and Prices.....           | 63          |

### FOUNDATION PLANS

|                                       |    |
|---------------------------------------|----|
| How to mount on solid foundation..... | 55 |
|---------------------------------------|----|

### MISCELLANEOUS INFORMATION

|                                         |    |
|-----------------------------------------|----|
| Rule for figuring size of pulleys.....  | 56 |
| If you mount engine on trucks, see..... | 56 |
| Capacity of fuel tanks.....             | 56 |

## High Quality

From its inception Hercules engine has held the foremost position in the Gas Engine industry. Commencing when the industry was in its infancy, it has been manufactured upon well-defined principles. Those principles have always been closely followed, with the result that our factory has grown to be the largest and best equipped Gas Engine plant in the world, and our line has been firmly entrenched in its commanding position.

This plant in its equipment of fine machinery, fine tools, jigs, fixtures and appliances is not equalled in the gas engine industry. This equipment includes a large battery of automatic labor-saving machines. Of these, many are capable of turning out from two to ten times the volume of work produced by the ordinary methods—an important factor in making possible the price, and an important factor in making possible the quality.

The system of inspection is so exacting that it practically precludes the possibility of an imperfect part being incorporated in the engine so far as can be detected by the most accurate measuring instruments known to engineering science. From the time the raw materials reach the warehouse and foundry until they leave the plant in the finished product, they are under the careful scrutiny of a corps of experts trained in accordance with the high standards of the organization. This inspection extends to the smallest pieces, including nuts, bolts and screws.

This engine has never had embodied in its makeup, features whose value was confined to their use as "talking points." It finds its sale not especially among purchasers whose limit of investment is the price. It appeals alike to the discriminating buyer who demands a dollar's worth for every dollar of investment, and to the buyer who places dependability and service above all price consideration.

It is the most sturdy and dependable of all gas engines. It is an engine of enduring service. In economy of operation and maintenance there is none that enjoys a favorable comparison with it. In real and substantial gas engine value it has no equal.